

Typical Finished Basement Details

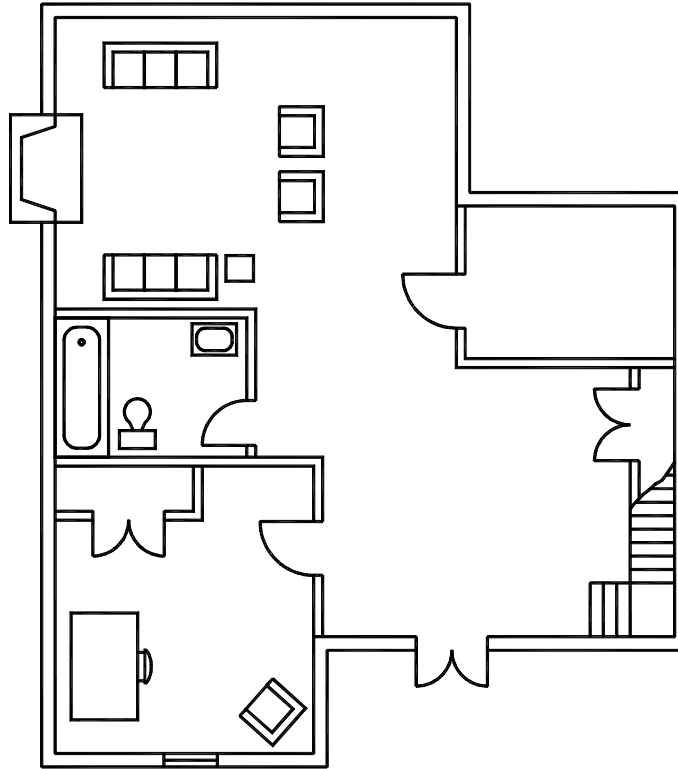

Typical Finished Basement Details

CONTENTS



Section	Page
1 General Notes	3
2 Emergency Escape and Rescue	3
3 Wall Construction.....	4
4 Drilling and Notching.....	6
5 Floor/ceiling Construction.....	7
6 Mechanical	7
7 Plumbing	8
8 Electrical.....	9

SECTION 1: GENERAL NOTES

1. Habitable rooms (excluding closets, hallways, laundry rooms, storage spaces and bathrooms) shall have an area of not less than 70 square feet and shall not be less than 7 feet in any direction.
2. Hallways shall not be less than 36 inches in width.
3. Basement ceiling height shall not be less than 7 feet above the finished floor. Structural members spaced 4 feet or more apart may project up to 6 inches below the required ceiling height.
4. Bathrooms shall be equipped with a fan vented directly to the outside. A fan is not required if the bathroom contains a window with an opening of 1.5 square feet or more.
5. Space under stairs shall be protected with ½-inch drywall on the underside or with a non-accessible enclosure clad in ½-inch drywall.
6. A smoke alarm shall be installed in the basement and in each basement bedroom. New smoke alarms shall be interconnected so that when one is activated all will sound. Smoke alarms must be hardwired with a battery backup.
7. If adding a bedroom and the house is equipped with a gas-fired appliance, a carbon monoxide alarm shall be installed in the basement.
8. All basement stairs shall have a light source to illuminate all treads and landings. Lights shall be operated by a switch located at the top and bottom of the stairs.
9. A minimum of R-13 battened insulation (with a vapor barrier on the warm side of the wall) should be installed for the full height and length of the basement wall.

SECTION 2: EMERGENCY ESCAPE AND RESCUE

Where required. An emergency escape and rescue opening in the form of a window or door to the outside is required for all finished basements and in all bedrooms regardless of the house's age. However, openings in the bedroom may serve the entire basement.

If your basement does not currently have one of the emergency escape and rescue options below, then you must provide one. **Cutting openings in existing basement walls is outside the scope of these details. Therefore, a plan submission is required for the new openings only.** All other conditions of the finished basement may be taken from these details.

Emergency escape and rescue options. The following openings can be used for emergency escape and rescue.

- Window opening in a walk-out basement condition.
- Window opening into a window well or areaway.
- Door in a walk-out basement condition.
- Door opening to an areaway.
- Door to bulkhead enclosure (Bilco door or similar).

Opening requirements. The emergency escape and rescue opening shall meet the requirements below.

- See FIGURE 1 for typical window opening requirements.
- All doors and windows must be operable from the inside without the need of a key or tool.
- The opening must be a minimum of 5.7 square feet.
- Windows must have a sill 44 inches or less above the finished floor.

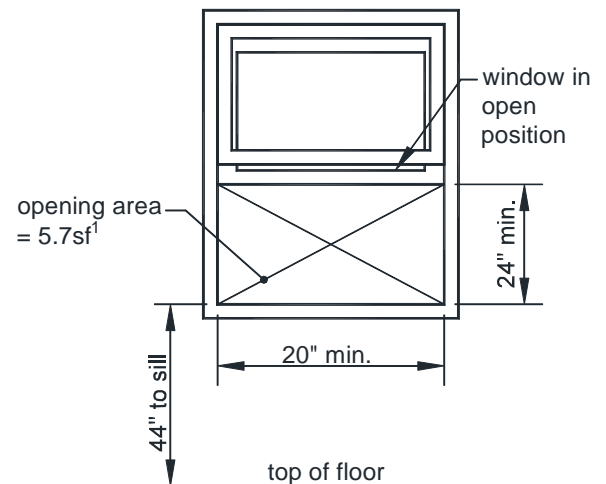

¹ Windows opening directly to outside in a walk-out condition are permitted to have an opening area equal to 5.0 square feet.

FIGURE 1: EMERGENCY ESCAPE AND RESCUE OPENING REQUIREMENTS

Window well requirements. When grade conditions require the sill of the window to be below the outside grade elevation, then a window well must be constructed. The required horizontal area of a window well is a minimum of 9 square feet minimum as measured when the window is in the open position (this is important when the window is a crank-out type). See FIGURE 2.

Window well construction. A plan submission to the county is required for the construction of a new window well. You may use the Fairfax County [Typical Retaining Wall Details](#) for guidance. If you choose to use a prefabricated window well, you must submit the manufacturer's specification during the permit application process.

Ladder requirements. When a window well is deeper than 44 inches, a permanent, attached ladder or steps must be provided per FIGURE 2. If the ladder projects more than 6 inches into the required horizontal area, the size of the window well must be increased to compensate.

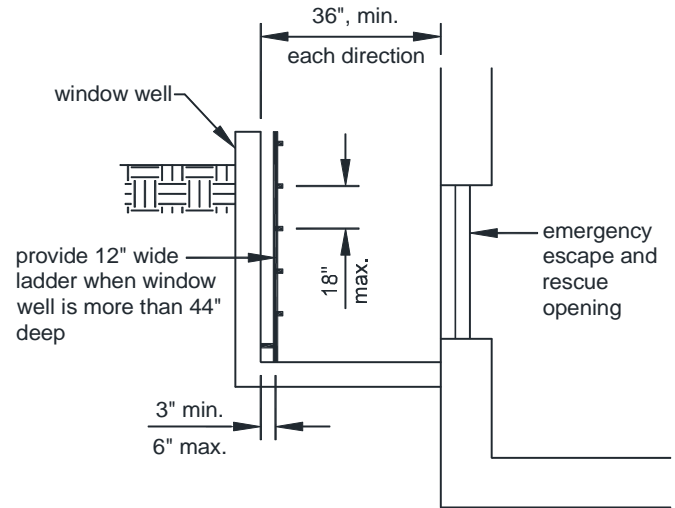

FIGURE 2: WINDOW WELL REQUIREMENTS

SECTION 3: WALL CONSTRUCTION

Studs. Studs may be utility grade or better. Walls shall have a single pressure treated bottom plate and can have a single or double top plate. Studs shall be placed at 16 inches on center, but may be increased to a 24 inches on center when applied finish material is drywall.

Attachment requirements. Wall construction shall be fastened in accordance with TABLE 1.

TABLE 1: FASTENING SCHEDULE

CONNECTION	NAILING METHOD	FASTENER
Top plate to stud	End nail	2-16d (3½" x 0.135")
Stud to bottom plate	Toe nail or	2-16d (3½" x 0.135") ¹ or
	End nail	3-8d (2½" x 0.113") ¹
Bottom plate to floor	Face nail	2-16d (3½" x 0.135") ¹
Header to jack stud (see FIGURE 3)	Toe nail	16d concrete nail (3½" x 0.135") @ 16"o.c. 4-8d (2½" x 0.113") each side of header at each end

¹Fasteners are required to be hot-dipped galvanized.

Headers. A single flat 2x4 may be used as a header in interior nonbearing walls for openings up to 8 feet in width if the portion of the wall above the opening is not more than 24 inches in height. If the opening does not meet these conditions, the header shall be framed per FIGURE 3 and sized per TABLE 2. Two-ply headers shall be fastened together using 16d (3½" x 0.135") face nails at 16 inches on center staggered along the top and bottom edges.

TABLE 2: HEADER SIZE¹

HEADER SIZE	SPAN LENGTH
(2)2x4	4'
(2)2x6	6'
(2)2x8	10'
(2)2x10	12'
(2)2x12	16'

¹Non-load bearing walls only.

Fireblocking. Fireblocking shall be provided to seal off concealed spaces and to form an effective fire barrier between stories. Fireblocking shall be provided in the following locations.

- In concealed spaces of stud walls and partitions, including furred spaces at the ceiling and floor level where the top plate is attached to the underside of the floor joists. See FIGURE 4.
- At all interconnections between concealed vertical and horizontal spaces such as occur at soffits, bulkheads, drop ceilings, etc. See FIGURE 5.
- In concealed spaces of stud walls offset from the basement wall. See FIGURE 6
- In concealed spaces between stair stringers at the top and bottom of the stair run.
- At gaps and openings around vents, pipes and ducts at the ceiling and floor level.

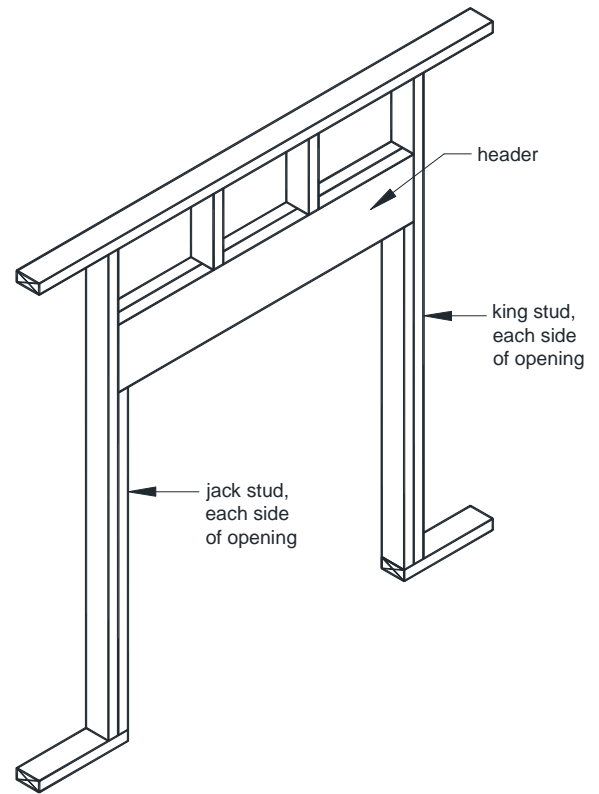
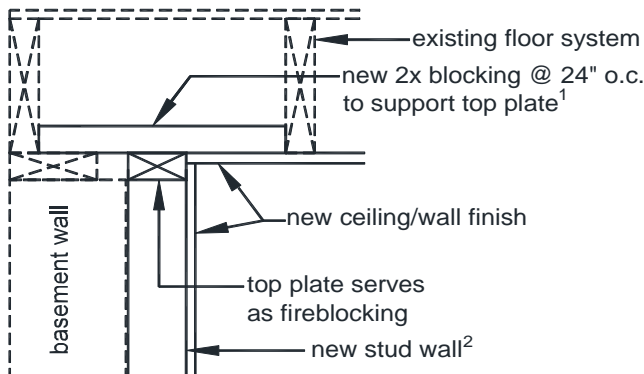

FIGURE 3: FRAMING AT HEADERS

Fireblocking material. Fireblocking shall consist of one of the materials listed below.

- ½-inch gypsum board.
- 2x lumber (2x4, 2x6, etc.).
- Two thicknesses of 1x lumber (1x4, 1x6, etc.) with staggered joints.
- ¾-inch plywood, OSB or particleboard with joints backed by 6 inches of the same material.
- ¼-inch cement, cement/fiber board (e.g., Durock).
- At gaps 1 inch or less, batts or blankets of mineral wool or fiberglass pack tightly or approved fireblocking caulk.



¹ Attach top plate to underside of joists where floor framing is perpendicular to stud wall.

² R-13 insulation should be provided between studs.

FIGURE 4: FIREBLOCKING WITH STUD WALL AGAINST BASEMENT WALL

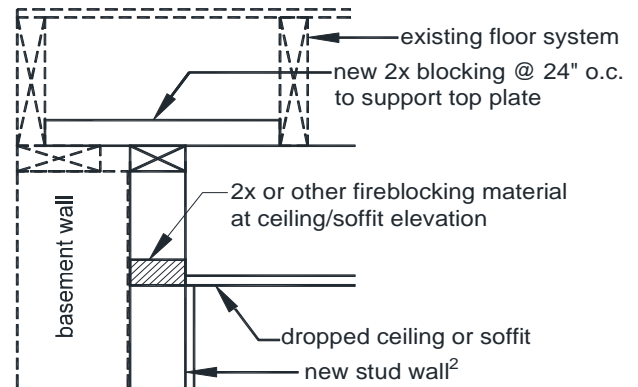

¹ Attach top plate to underside of joists where floor framing is perpendicular to stud wall.

² R-13 insulation should be provided between studs.

FIGURE 5: FIREBLOCKING AT DROP CEILING

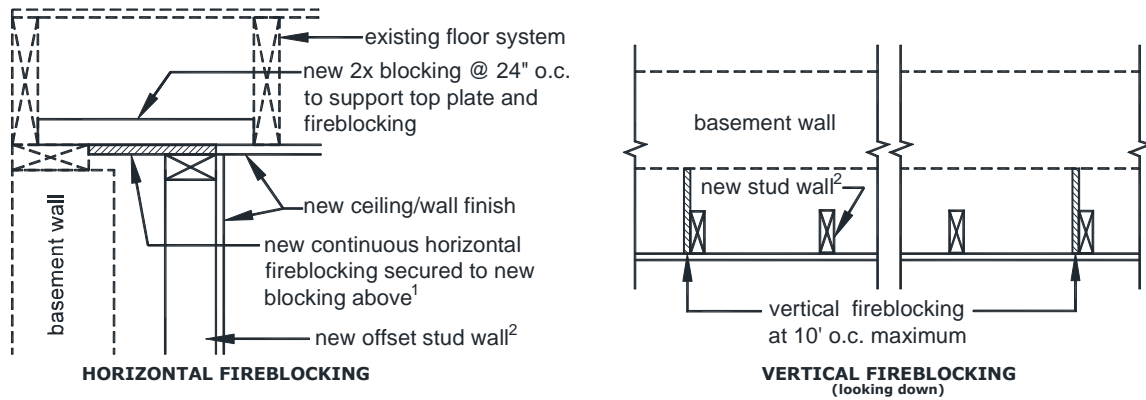

¹ Attach top plate and fireblocking to underside of joists where floor framing is perpendicular to stud wall.
² If cavity between basement wall and new stud wall does not contain existing insulation it must be fire stopped.

FIGURE 6: FIREBLOCKING WITH OFFSET STUD WALL

Interior finishes. Wall and ceiling finish materials must meet the requirements listed below.

- Materials must have a flame spread classification no greater than 200 and a smoke density classification no greater than 450. This does not apply to trim, molding, handrails and doors.
- Cement or fiber-cement board (e.g., Durock) must be installed on walls of bathtub and shower spaces and finished with a non-absorbent surface.
- Wood veneer or hardboard paneling less than 1/4-inch shall not be permitted.
- Gypsum board must be 1/2-inch minimum.

SECTION 4: DRILLING AND NOTCHING

Studs. Studs in non-load bearing walls may be notched or drilled in accordance with FIGURE 7.

Joists and/or beams. Drilling and notching of existing wood joists or beams shall meet the requirements below.

- Drilling and notching 2x lumber shall be in conformance with FIGURE 8. Cantilevered (overhanging) joists cannot be notched.
- Drilling and notching of manufactured wood I-joists, LVL or other engineered wood product shall be per the manufacturers' instructions.
- Drilling and notching of open web floor trusses is prohibited without submitted calculations performed by a registered design professional licensed in Virginia.

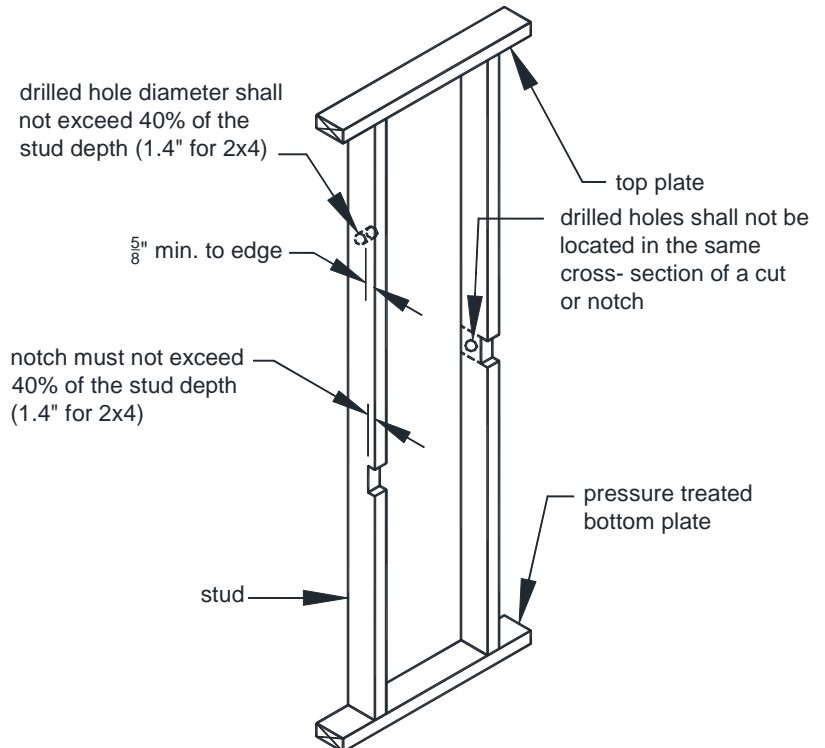

FIGURE 7: DRILLING AND NOTCHING STUDS

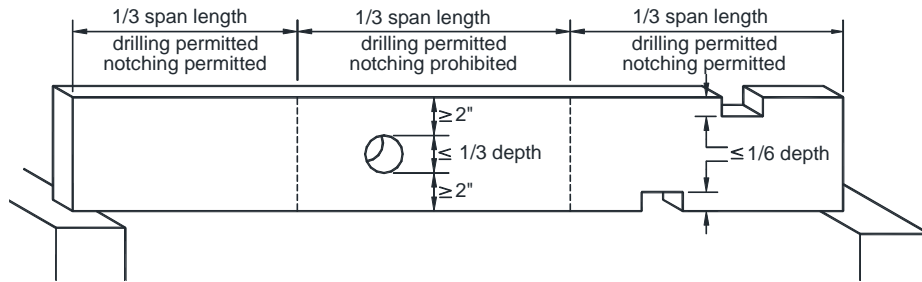

FIGURE 8: DRILLING AND NOTCHING JOISTS

SECTION 5: FLOOR/CEILING CONSTRUCTION

Draftstopping. When a ceiling is not directly attached to the underside of the floor joists above or when the floor joists are comprised of open web trusses, draftstopping must be provided. Install draftstopping to create equal-sized concealed areas not exceeding 1,000 square feet. Draftstopping shall be installed parallel to the floor framing members. See FIGURE 9 and FIGURE 10.

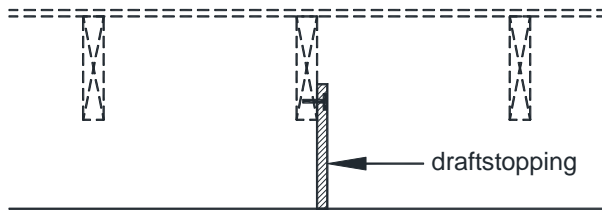

FIGURE 9: DRAFTSTOPPING AT DROP CEILING

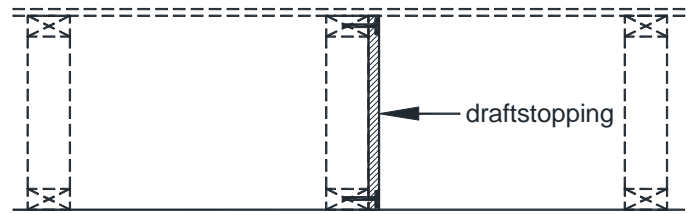

FIGURE 10: DRAFTSTOPPING AT OPEN WEB TRUSSES

Draftstopping material. Draftstopping shall consist of 1/2-inch minimum gypsum board, 3/8-inch minimum wood plywood/OSB or 3/8-inch minimum particleboard, Type 2-M-W.

SECTION 6: MECHANICAL

Appliance access. Furnaces, water heaters and other appliances must be accessible without removing permanent construction and shall meet the following minimum criteria.

- 30 inches x 30 inches clear floor space at front/control side.
- Doors to furnace rooms shall be 24 inches minimum and be of sufficient size to remove the largest appliance.

Combustion air. Furnace rooms with fuel-fired appliances must be provided with two permanent openings to adjacent spaces: one within 12 inches of the top and one within 12 inches from the bottom of the adjoining wall. Each opening must have a minimum free area equal to 1 square inch per 1,000 Btu per hour input rating of all appliances in the furnace room, but not less than 100 square inches. The openings are not required if a louvered door is provided or the furnace room area is greater than 50 cubic feet per 1,000 Btu per hour input rating of all appliances installed in the room.

Showers. Showers and shower compartments must meet the following requirements.

- Shower compartments must have a minimum total area of 900 square inches and a minimum dimension of 30 inches in any direction.
- Shower compartments may have a minimum dimension of 25 inches provided it maintains a cross sectional area of 1,300 square inches.
- Hinged shower doors must open outward.
- All glass which encloses as shower must be safety glazed.
- Shower control valves must be scald resistant (in accordance with ASSE/ANSI 1016) with a hot water limit of 120 degree F.

Fixture clearances. Toilets, sinks and showers shall have the minimum clearances listed below.

- 21 inches in front of sinks and toilets.
- 24 inches in front of shower stall opening.
- 4 inches between two adjacent sinks.
- 4 inches between a sink and a toilet.
- 4 inches between a sink and a wall.
- 2 inches between a sink and a bathtub.
- 15 inches clearance from a toilet's centerline to an adjacent fixture or wall on each side.

Drain size. Fixture drain size must meet the dimensions below and must be equipped with a strainer and stopper.

TABLE 3: MINIMUM DRAIN SIZE

FIXTURE	DIAMETER
Bathroom sink	1¼"
Bathtubs	1½"
Sinks (other than bathroom)	1½"
Laundry tubs	1½"
Shower	1½"

Clothes washer discharge. The discharge of a clothes washer must be through and air break as shown in FIGURE 11.

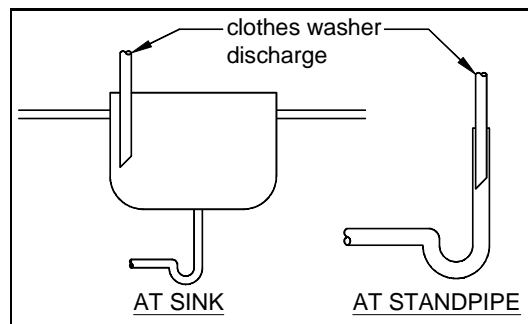

FIGURE 11: AIRBREAK AT CLOTHES WASHER DISCHARGE

Panelboard (circuit breaker box). Panel boards must meet the requirements listed below.

- A workspace 30 inches wide and 36 inches deep from floor to the ceiling with a minimum height of 6.5 feet shall be provided in front of the panel boards.
- Panel board workspace must not be used for storage at any time.
- Panel boards must not be located in clothes closets or bathrooms.
- A light shall be provided for the panel board workspace.
- Pipes or ducts cannot be located above the panelboard.

Branch circuits. Branch circuits must meet the requirements listed below. See TABLE 4 for more information.

- Use a 15- to 20-ampere rated branch circuit for general use purposes such as lighting and outlets.
- One “plugged-in” electrical device shall not exceed 80 percent of the circuit rating.
- Hardwired appliances or equipment may be included in a general use circuit provided its rating does not exceed 50 percent of the circuit rating.
- A dedicated 20-ampere minimum branch circuit must be provided to serve laundry room outlets only.
- A dedicated 20-ampere branch circuit must be provided to serve the bathroom receptacles.
- Branch circuits which serve bedroom outlets must have circuit breakers equipped as combination arc-fault/over current circuit interrupters.

TABLE 4: BRANCH CIRCUIT REQUIREMENTS

Circuit Element	Circuit Rating		
	15 amp	20 amp	30 amp
Minimum conductor size	14	12	10
Maximum breaker size	15	20	30
Outlets rating	15	15 or 20	30
Maximum load	15	20	30

Lighting requirements. Lights must meet the requirements listed below.

- At least one switched light shall be provided in each room and hallway. A switched outlet may be substituted except in bathrooms and hallways. A switched outlet cannot count towards a required outlet, see “Outlets” on page 10.
- At least one switched or pull chain light must be provided in each storage area and at or near heating and air conditioning appliances and equipment.
- Lighting fixtures must not be installed within 3 feet horizontally and 8 feet vertically of a bathtub rim or shower stall threshold. A light fixture may be installed above a shower area if it is constructed so that water cannot enter or accumulate in wiring areas and the lighting fixture is marked “suitable for wet locations.”

Outlets. Outlets must meet the requirements listed below.

- Outlets shall be tamper resistant.
- Outlets shall be placed in accordance with FIGURE 12.
- The minimum wall length which requires an outlet is 2 feet.
- Kneewalls, built-in bars and other fixed room dividers must be included for outlet spacing.
- Hallways more than 10 feet long must have a minimum of one outlet.
- Outlets installed for specific appliances must be within 6 feet of the appliance location.
- Bathrooms must have at least one outlet located on a wall adjacent to each basin and within 36 inches of the bathroom sink. All bathroom outlets must have ground fault circuit interrupter (GFCI) protection.
- At least one outlet must be provided to serve laundry appliances and sinks.
- Each unfinished portion of the basement is required to have at least one outlet that is GFCI protected.
- An outlet must be provided within 25 feet of heating and air conditioning appliances and equipment.

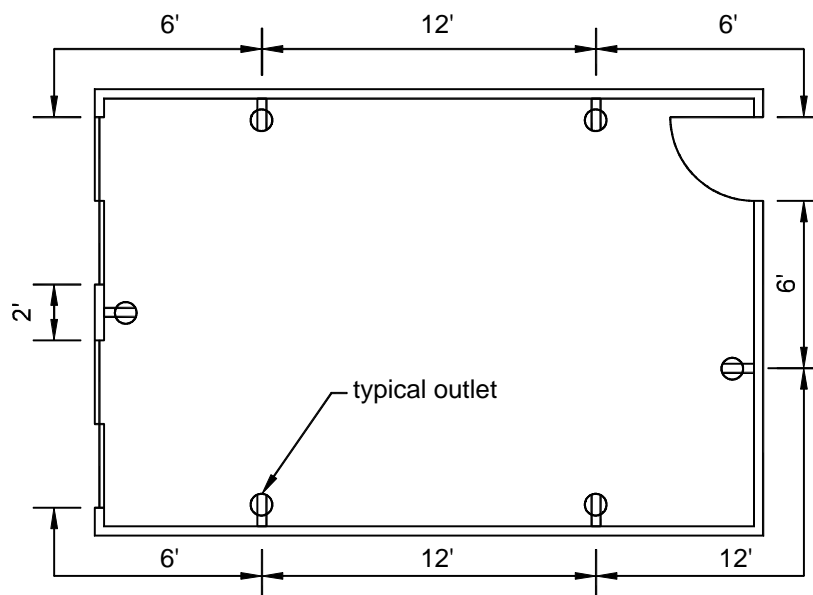

FIGURE 12: TYPICAL OUTLET DISTRIBUTION

Light fixtures in closets. Fixtures installed in clothes closets shall be limited to surface mounted or recessed incandescent fixtures with completely enclosed lamps and surface mounted or recessed fluorescent fixtures. See TABLE 5 for clearance requirements.

TABLE 5: CLOSET LIGHT FIXTURE CLEARANCES¹

Fixture Type	Fluorescent Bulb ²	LED Bulb ²
Surface mounted	6"	12"
Recessed	6"	6"

¹ Incandescent bulbs are prohibited.

² Fluorescent and LED bulbs are permitted in storage areas when identified for this use.

FINISHED BASEMENT PLANS **MINIMUM INFORMATION REQUIRED**

Show entire area finished/unfinished including any garage. LABEL ALL AREAS.
Plan to show stairway details including headroom, width, risers, treads and handrails.
Plans to have dimensions for all areas with the location of all mechanical equipment.

Furnace: no access allowed through bathroom or bedroom. Provide combustion air based on BTU's of furnace. Exceptions – direct vent appliance. (See attached sheet.)

Electric panel not allowed in bathrooms or closets, working space 30" wide and 36" in front of panel from floor to 6' 6" high. (Nothing can be located in this space.)

Provide drawing of wall showing size and spacing of members. Indicate pressure treated sill; fire blocking, and wall finish. (See attached sheet.)

*In new construction required ceiling height for finished basement shall be 7' with any projections downward not to exceed 6". For existing unfinished basement conversion to finished, required ceiling height is 6' 10" minimum, and beams and girders shall provide not less than 6' 6" clear ceiling height. **For Stairways**: In **new** construction minimum headroom for all parts of stairway to **finished** basement shall not be less than 6' 8". Minimum headroom in all parts of **existing or replacement stairways** serving existing unfinished basements being converted to habitable space shall be 6' 6".*

Common wall garage to living requires 5/8" fire code sheetrock. Doors to be 1 1/2" solid wood, 1 1/2" solid or honeycomb core steel door or 20-minute fire rated door and shall be fitted with self-closing device.

Storage under stairway requires one layer of 1/2" sheetrock.

Smoke and carbon monoxide detectors shall be provided on all levels and all bedrooms, or provide note on your plan if they already exist in required locations.

Egress Window – One each in each sleeping room and must meet all of the following:

1. 20" minimum clear opening width.
2. 24" minimum clear opening height
3. 5.7 sq. ft. or 820.8 sq. inches
4. 44" maximum window sill height above floor

Indicate if window is tilt and takeout, manufacturer and style: double hung, casement, or slider.

Insulation shall comply with R-13 for walls.

State modification required when you cannot comply with the code. Form must be completed by applicant and returned to this office for submission for approval.

COMBUSTION AIR

Direct vent appliances and appliances equipped with a combustion air kit do not require additional combustion air.

All fuel-burning appliances (furnaces, hot water heaters, etc.) require air for combustion based on 50 cubic feet of air for each 1,000 BTU's of appliance(s).

The air may be taken from the space where the appliance(s) is located if sufficient or adjacent spaces (if volume is sufficient and connected by two openings of required size).

To see if you comply, please do the following calculation below for your space.

Length _____ X Width _____ = Area _____ X Height _____ = SPACE VOLUME in cubic feet _____.

BTU's of your appliance(s) _____ X 50 Cu. Ft. = required VOL. in cubic feet _____.
1000

SPACE VOL. of air _____

APPLIANCE VOL. of air _____

The volume of air required for the appliance(s) must be equal to or less than the SPACE VOL. of air. If the space volume of air is less (not enough combustion air) outside air is required.

Connected spaces require two openings.

One opening must be located 12" from the floor; the other must be located 12" from the ceiling.

Each opening shall have a clear opening equal to 1 sq. inch per 1,000 BTU's, but not be less than 100 sq. inches.

Calculations for openings:

Appliance BTU's _____ X 1 sq. inch = _____ sq. inch of opening.
1000

Metal louvers are 75% efficient. Wood louvers are 25% efficient. Use calculations below for the type of louvers used.

Metal _____ sq. inch of opening (divided by) .75 = _____ required size of louver in sq. inches.

Wood _____ sq. inch of opening (divided by) .25 = _____ required size of louver in sq. inches.