

# SITE DEVELOPMENT PLANS

## THREE TWO-BEDROOM UNITS

### 8-30g DEVELOPMENT

### 72 RESERVOIR STREET

### BETHEL - CONNECTICUT

### PREPARED FOR

### D3 REALTY

### DATE: FEBRUARY 11, 2025

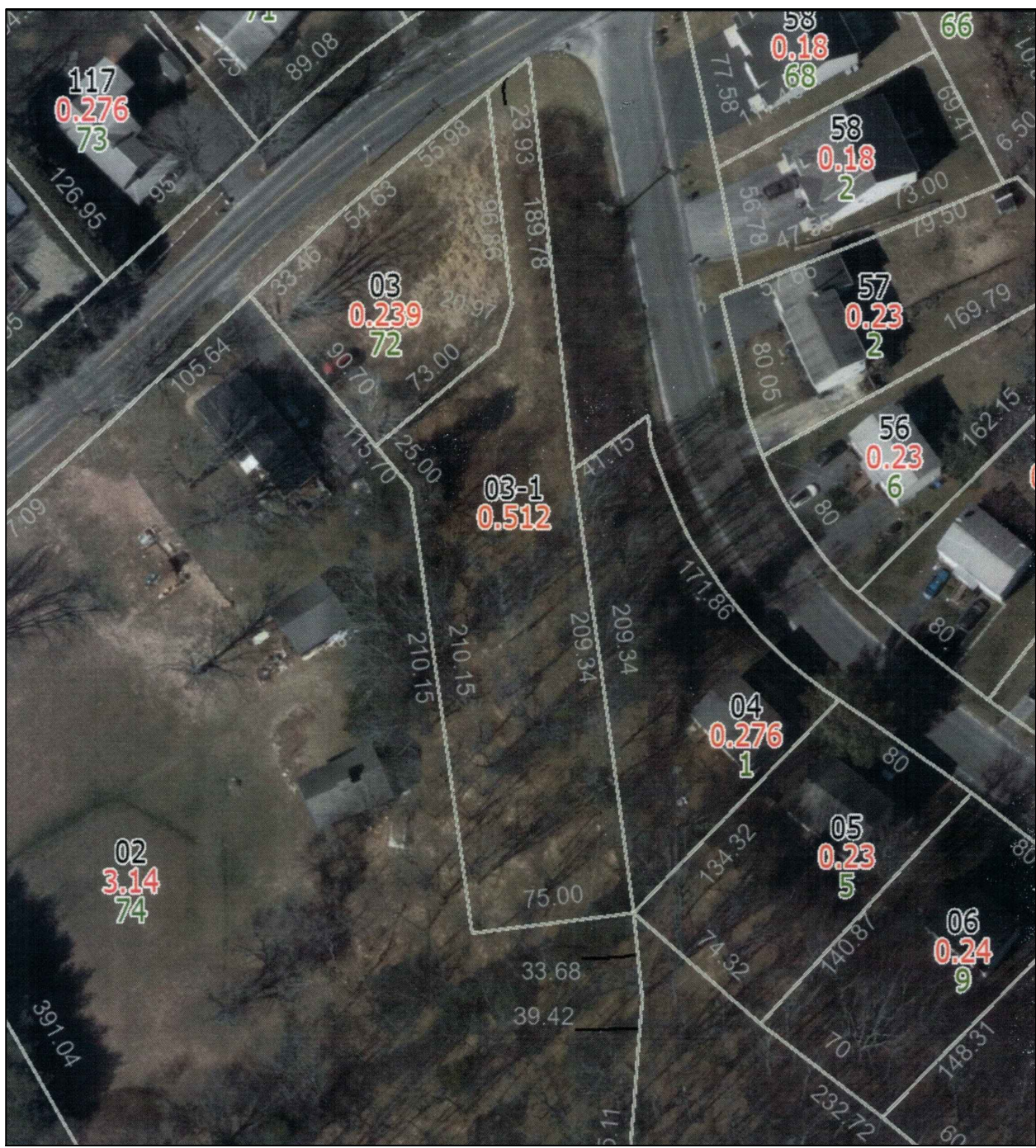

TOWN OF BETHEL GIS MAPPING  
NOT TO SCALE

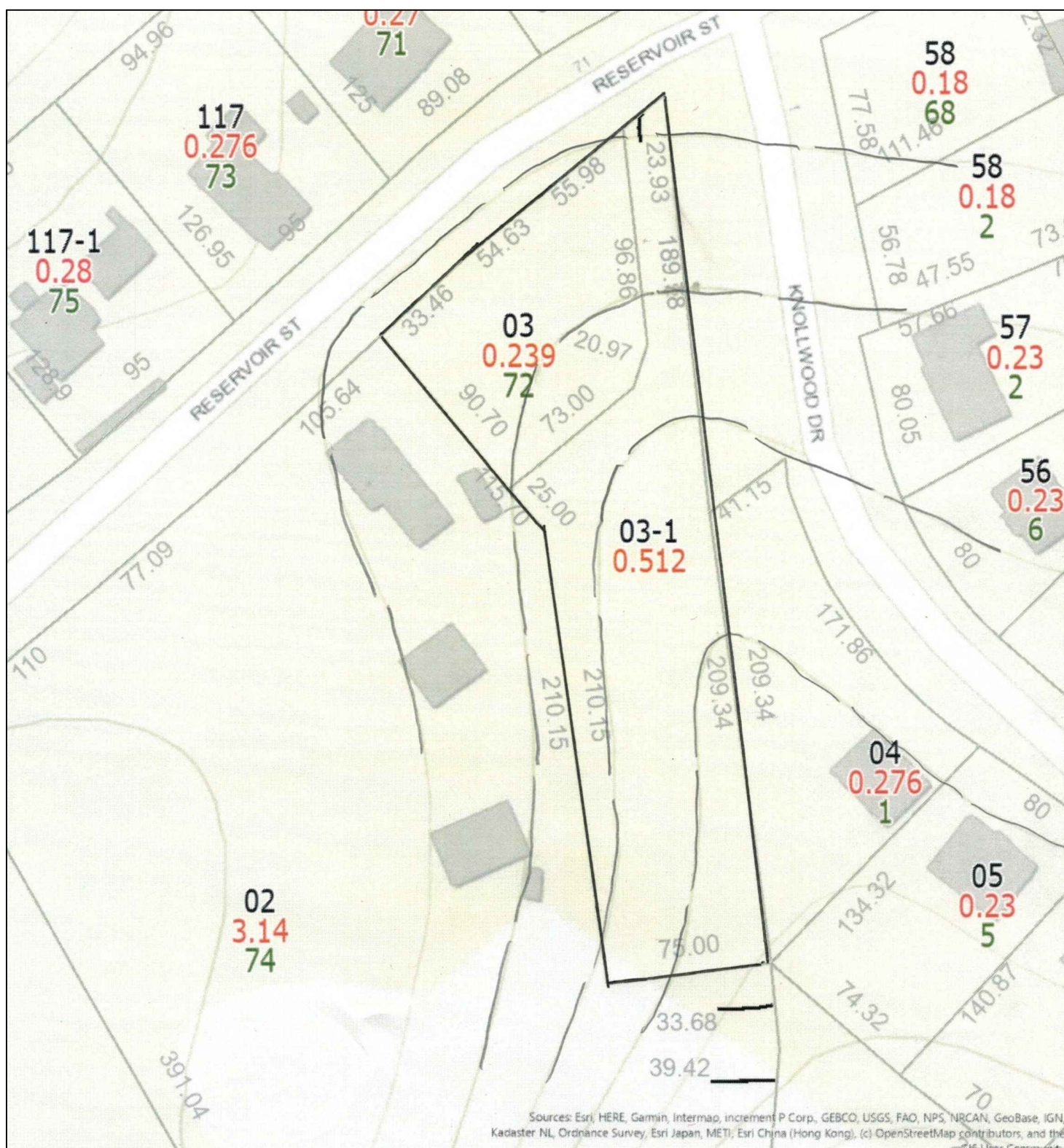

TOWN OF BETHEL GIS MAPPING  
NOT TO SCALE

CALCULATED SEWER FLOWS:  
3 THREE-BEDROOM UNITS AT 400 GALLONS PER DAY = 2,700 GPD  
2,700 GPD = 0.004 CUBIC FEET PER SECOND (CFS)

SITE VOLUME COMPUTATIONS  
EARTH/ROCK CUT = 10,100 CUBIC YARDS  
EARTH FILL VOLUME = 135 CUBIC YARDS

PARKING INFORMATION:  
3 TWO-BEDROOM UNITS  
2 PARKING SPACES PER UNIT PROVIDED (TOTAL SIX SPACES)

*Important Note:*  
Additional underground utilities may exist  
Prior to any excavation or construction,  
contact: "CALL BEFORE YOU DIG" 1-800-922-4455 or 811











- LIST OF PLAN SHEETS  
DATE: JANUARY 25, 2025  
SHEET-1: EXISTING CONDITIONS PLAN  
SHEET-2: SITE UTILITIES PLAN  
SHEET-3: STORMWATER MANAGEMENT PLAN  
SHEET-4: SITE GRADING/EROSION PLAN  
SHEET-5: CONSTRUCTION DETAILS  
SHEET-6: CONSTRUCTION NARRATIVE  
SHEET-7: CROSS SECTIONS  
SHEET-8: SIGHT DISTANCE PLAN

PLAN REVISIONS:  
STAFF COMMENTS: 5/12/25  
SIGHT LINES: 6/15/25  
MODIFICATIONS: 9/21/25  
MODIFICATIONS: 12/3/25

**TRINKAUS ENGINEERING, LLC**  
CIVIL ENGINEERS  
114 HUNTERS RIDGE ROAD  
SOUTHBURY, CONNECTICUT 06488  
203-264-4558 (phone)  
Email: [strinkaus@earthlink.net](mailto:strinkaus@earthlink.net)  
Website: <http://www.trinkausengineering.com>



**LEGEND**

-  MAILBOX
-  UTILITY POLE
-  WATER VALVE
-  SANITARY SEWER MANHOLE
-  BOLLARD LIGHT (PROPOSED)
-  CATCH BASIN (EXISTING)
-  SILTATION FENCE BARRIER (PROPOSED)
-  FILTRIX SOXX (PROPOSED)
-  STREET SIGN (EXISTING)
-  UTILITIES (EXISTING)

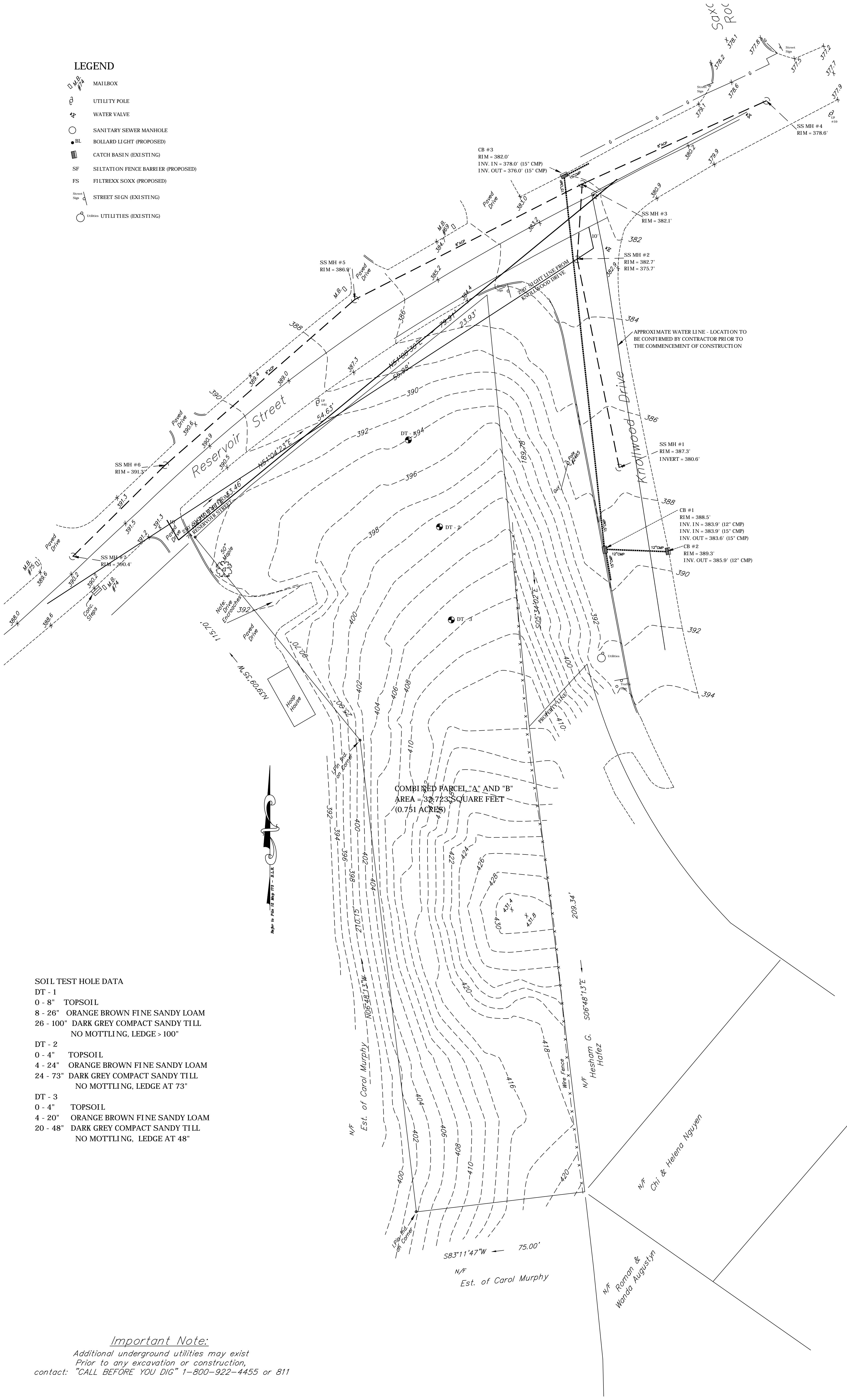











**SOIL TEST HOLE DATA**

DT - 1	0 - 8" TOPSOIL
	8 - 26" ORANGE BROWN FINE SANDY LOAM
	26 - 100" DARK GREY COMPACT SANDY TILL
	NO MOTTLING, LEDGE > 100"
DT - 2	0 - 4" TOPSOIL
	4 - 24" ORANGE BROWN FINE SANDY LOAM
	24 - 73" DARK GREY COMPACT SANDY TILL
	NO MOTTLING, LEDGE AT 73"
DT - 3	0 - 4" TOPSOIL
	4 - 20" ORANGE BROWN FINE SANDY LOAM
	20 - 48" DARK GREY COMPACT SANDY TILL
	NO MOTTLING, LEDGE AT 48"

Important Note:  
 Additional underground utilities may exist  
 Prior to any excavation or construction,  
 contact: "CALL BEFORE YOU DIG" 1-800-922-4455 or 811

**LEGEND**

-  MAILBOX
-  UTILITY POLE
-  WATER VALVE
-  SANITARY SEWER MANHOLE
-  BOLLARD LIGHT (PROPOSED)
-  CATCH BASIN (EXISTING)
-  SILTATION FENCE BARRIER (PROPOSED)
-  FILTREXX SOXX (PROPOSED)
-  STREET SIGN (EXISTING)
-  UTILITIES (EXISTING)

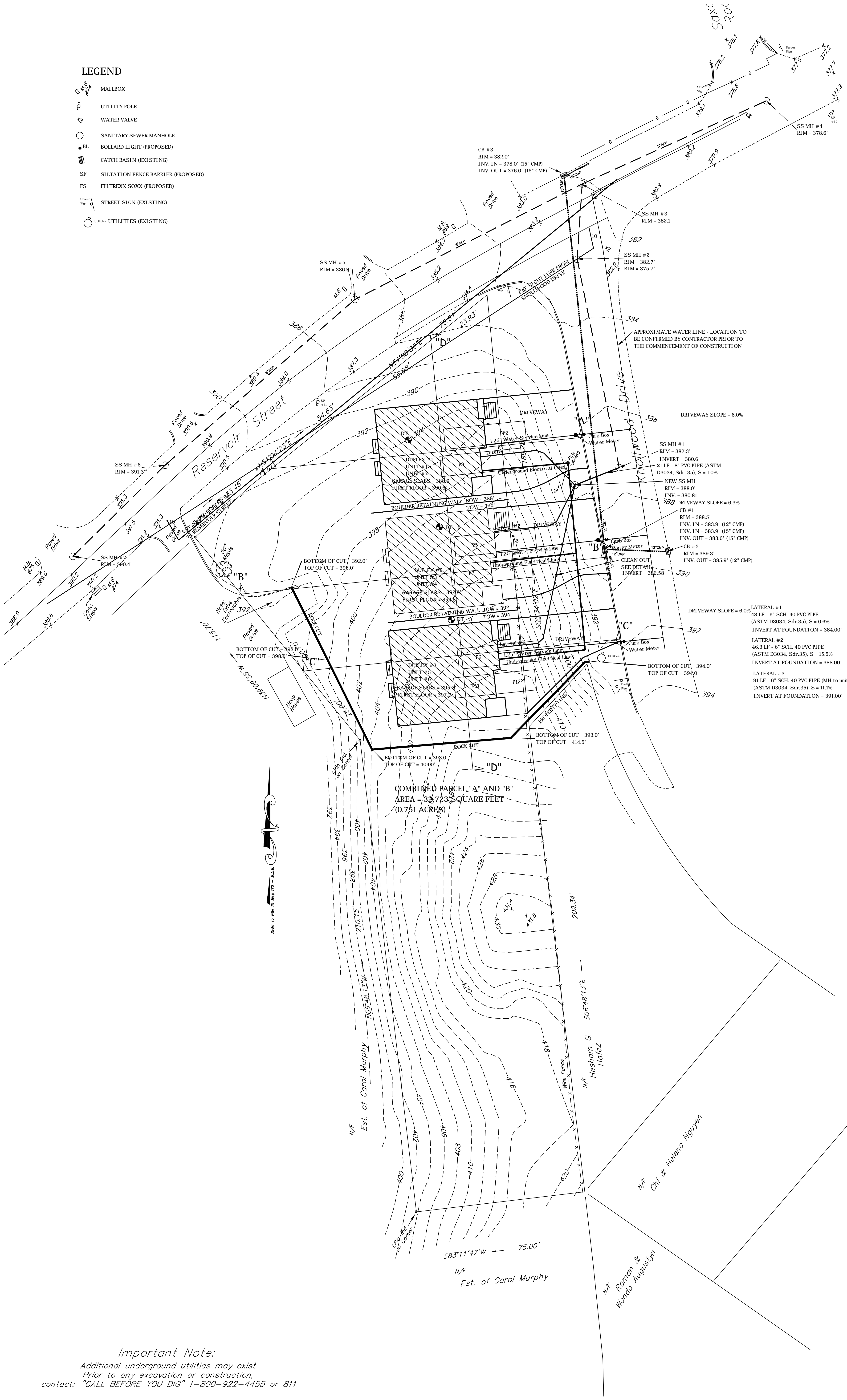

**Important Note:**  
 Additional underground utilities may exist  
 Prior to any excavation or construction,  
 contact: "CALL BEFORE YOU DIG" 1-800-922-4455 or 811

PREPARED FOR  
**D3 REALTY**  
 72 RESERVOIR STREET  
 BETHEL - CONNECTICUT

**UTILITY PLAN**

SHEET 2 OF 8  
 SCALE: 1" = 20'  
 PROJECT #042-2024  
 DATE: 2/11/25, Rev. to 12/3/25



**TRINKAUS ENGINEERING, LLC**  
 CIVIL ENGINEERS  
 114 HUNTERS RIDGE ROAD  
 SOUTHBURY, CONNECTICUT 06488  
 203-264-4558 (phone)  
 Email: strinkaus@earthlink.net  
 Website: <http://www.trinkaengineering.com>

**LEGEND**

- MAILBOX
- UTILITY POLE
- WATER VALVE
- SANITARY SEWER MANHOLE
- BOLLARD LIGHT (PROPOSED)
- CATCH BASIN (EXISTING)
- SILTATION FENCE BARRIER (PROPOSED)
- FILTREXX SOXX (PROPOSED)
- STREET SIGN (EXISTING)
- UTILITIES (EXISTING)

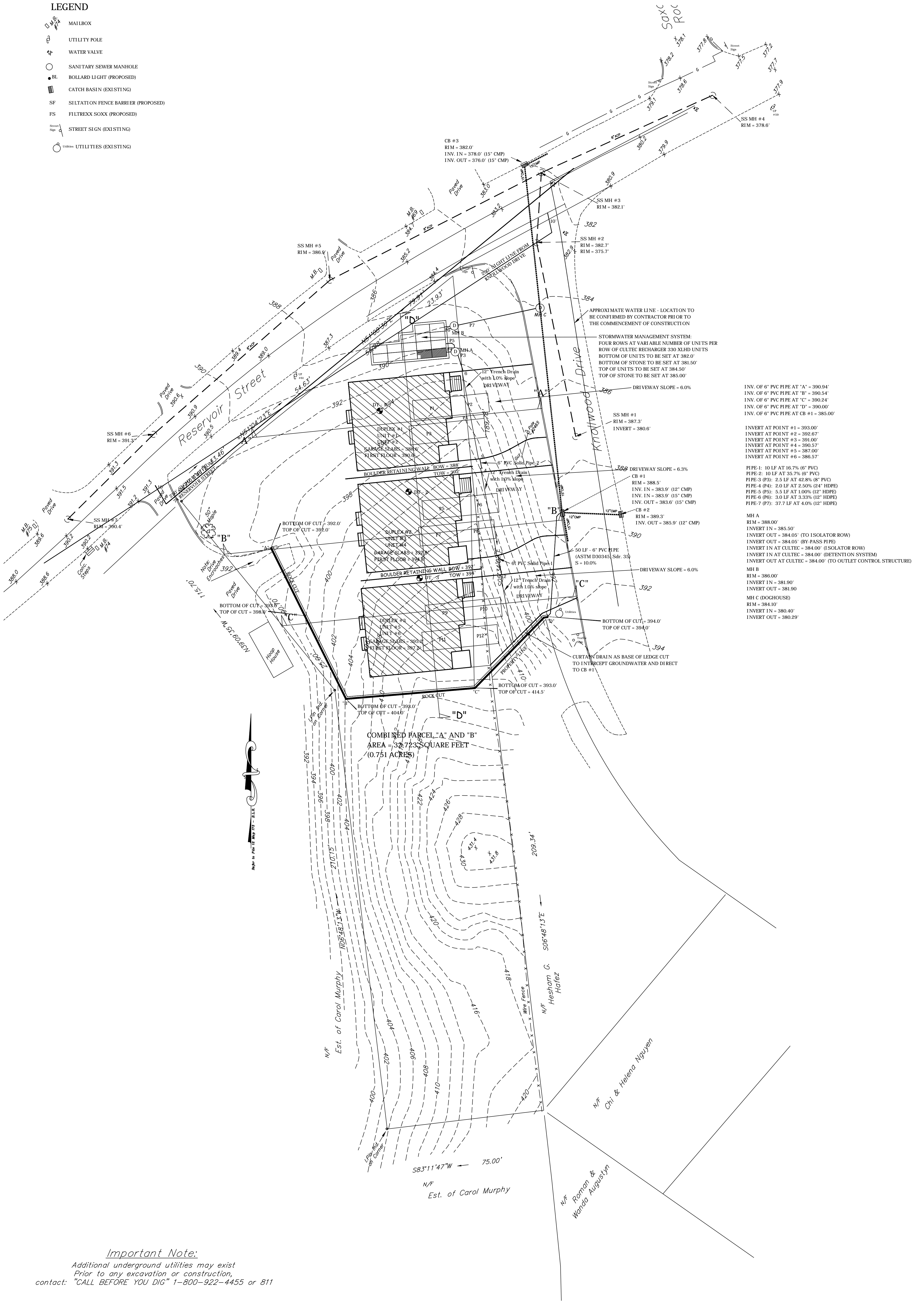

APPROXIMATE WATER LINE - LOCATION TO BE CONFIRMED BY CONTRACTOR PRIOR TO THE COMMENCEMENT OF CONSTRUCTION

STORMWATER MANAGEMENT SYSTEM:  
FOUR ROWS AT VARIABLE NUMBER OF UNITS PER ROW OF CULTEC RECHARGER 330 XLHD UNITS  
BOTTOM OF UNITS TO BE SET AT 382.0'  
BOTTOM OF STONE TO BE SET AT 381.50'  
TOP OF UNITS TO BE SET AT 384.50'  
TOP OF STONE TO BE SET AT 385.00'

DRIVEWAY SLOPE = 6.0%

DRIVEWAY SLOPE = 6.3%

DRIVEWAY SLOPE = 6.0%

DRIVEWAY SLOPE = 6.0%

PIPE-1: 10 LF AT 18.7% (6" PVC)  
PIPE-2: 10 LF AT 33.7% (6" PVC)  
PIPE-3 (P3): 2.5 LF AT 42.8% (8" PVC)  
PIPE-4 (P4): 2.0 LF AT 2.50% (24" HDPE)  
PIPE-5 (P5): 5.5 LF AT 1.00% (12" HDPE)  
PIPE-6 (P6): 3.0 LF AT 3.33% (12" HDPE)  
PIPE-7 (P7): 37.7 LF AT 4.0% (12" HDPE)

MH A  
RIM = 388.00'  
INVERT IN = 385.50'  
INVERT OUT = 384.05' (TO ISOLATOR ROW)  
INVERT OUT = 384.05' (BY-PASS PIPE)  
INVERT IN AT CULTEC = 384.00' (ISOLATOR ROW)  
INVERT IN AT CULTEC = 384.00' (DETENTION SYSTEM)  
INVERT OUT AT CULTEC = 384.00' (TO OUTLET CONTROL STRUCTURE)

MH B  
RIM = 386.00'  
INVERT IN = 381.90'  
INVERT OUT = 381.90'

MH C (DOGHOUSE)  
RIM = 384.10'  
INVERT IN = 380.40'  
INVERT OUT = 380.29'

COMBINED PARCEL "A" AND "B"  
AREA = 32,723 SQUARE FEET  
(0.751 ACRES)

**Important Note:**  
Additional underground utilities may exist  
Prior to any excavation or construction,  
contact: "CALL BEFORE YOU DIG" 1-800-922-4455 or 811











PREPARED FOR  
**D3 REALTY**  
72 RESERVOIR STREET  
BETHEL - CONNECTICUT

**STORMWATER PLAN**  
SHEET 3 OF 8  
SCALE: 1" = 20'  
PROJECT #042-2024  
DATE: 2/11/25, Rev. to 12/3/25



**TRINKAUS ENGINEERING, LLC**  
CIVIL ENGINEERS  
114 HUNTERS RIDGE ROAD  
SOUTHURY, CONNECTICUT 06488  
203-264-4558 (phone)  
Email: strinkaus@earthlink.net  
Website: http://www.trinkausengineering.com

**LEGEND**

-  MAILBOX
-  UTILITY POLE
-  WATER VALVE
-  SANITARY SEWER MANHOLE
-  BOLLARD LIGHT (PROPOSED)
-  CATCH BASIN (EXISTING)
-  SILTATION FENCE BARRIER (PROPOSED)
-  FILTREXX SOXX (PROPOSED)
-  STREET SIGN (EXISTING)
-  UTILITIES (EXISTING)

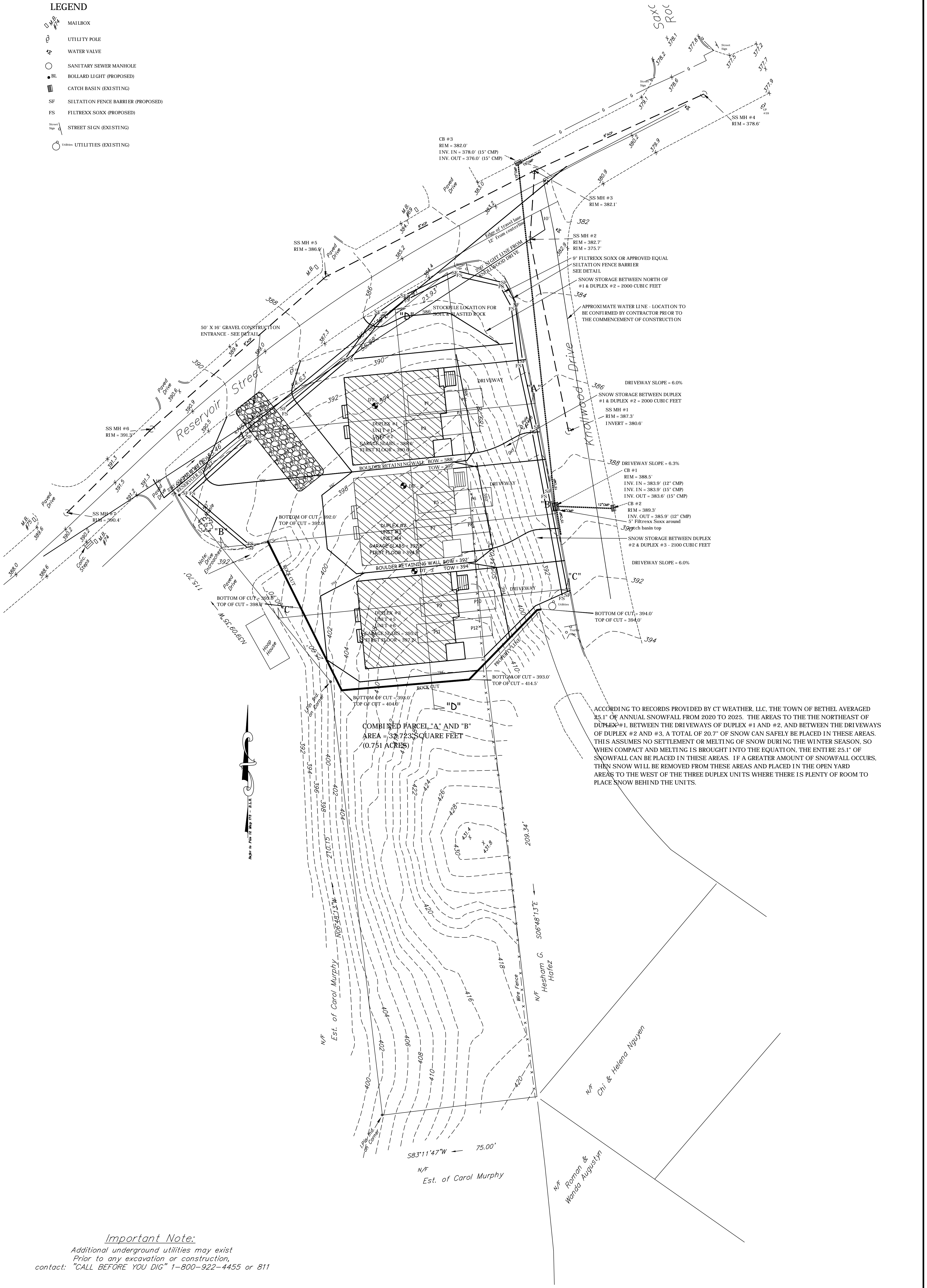

ACCORDING TO RECORDS PROVIDED BY CT WEATHER, LLC, THE TOWN OF BETHEL AVERAGED 25.1" OF ANNUAL SNOWFALL FROM 2020 TO 2025. THE AREAS TO THE THE NORTHEAST OF DUPLEX #1, BETWEEN THE DRIVEWAYS OF DUPLEX #1 AND #2, AND BETWEEN THE DRIVEWAYS OF DUPLEX #2 AND #3, A TOTAL OF 20.7' OF SNOW CAN SAFELY BE PLACED IN THESE AREAS. THIS ASSUMES NO SETTLEMENT OR MELTING OF SNOW DURING THE WINTER SEASON, SO WHEN COMPACT AND MELTING IS BROUGHT INTO THE EQUATION, THE ENTIRE 25.1' OF SNOWFALL CAN BE PLACED IN THESE AREAS. IF A GREATER AMOUNT OF SNOWFALL OCCURS, THEN SNOW WILL BE REMOVED FROM THESE AREAS AND PLACED IN THE OPEN YARD AREAS TO THE WEST OF THE THREE DUPLEX UNITS WHERE THERE IS PLENTY OF ROOM TO PLACE SNOW BEHIND THE UNITS.



**Important Note:**

Additional underground utilities may exist  
 Prior to any excavation or construction,  
 contact: "CALL BEFORE YOU DIG" 1-800-922-4455 or 811

PREPARED FOR  
**D3 REALTY**  
 72 RESERVOIR STREET  
 BETHEL - CONNECTICUT

**GRADING/EROSION PLAN**  
 SHEET 4 OF 8  
 SCALE: 1" = 20'  
 PROJECT #042-2024  
 DATE: 2/11/25, Rev. to 12/3/25



**TRINKAUS ENGINEERING, LLC**  
 CIVIL ENGINEERS  
 114 HUNTERS RIDGE ROAD  
 SOUTHURY, CONNECTICUT 06488  
 203-264-4558 (phone)  
 Email: strinkaus@earthlink.net  
 Website: http://www.trinkausengineering.com

**LEGEND**

- MAILBOX
- UTILITY POLE
- WATER VALVE
- SANITARY SEWER MANHOLE
- BOLLARD LIGHT (PROPOSED)
- CATCH BASIN (EXISTING)
- SILTATION FENCE BARRIER (PROPOSED)
- FILTREX SOXX (PROPOSED)
- STREET SIGN (EXISTING)
- UTILITIES (EXISTING)

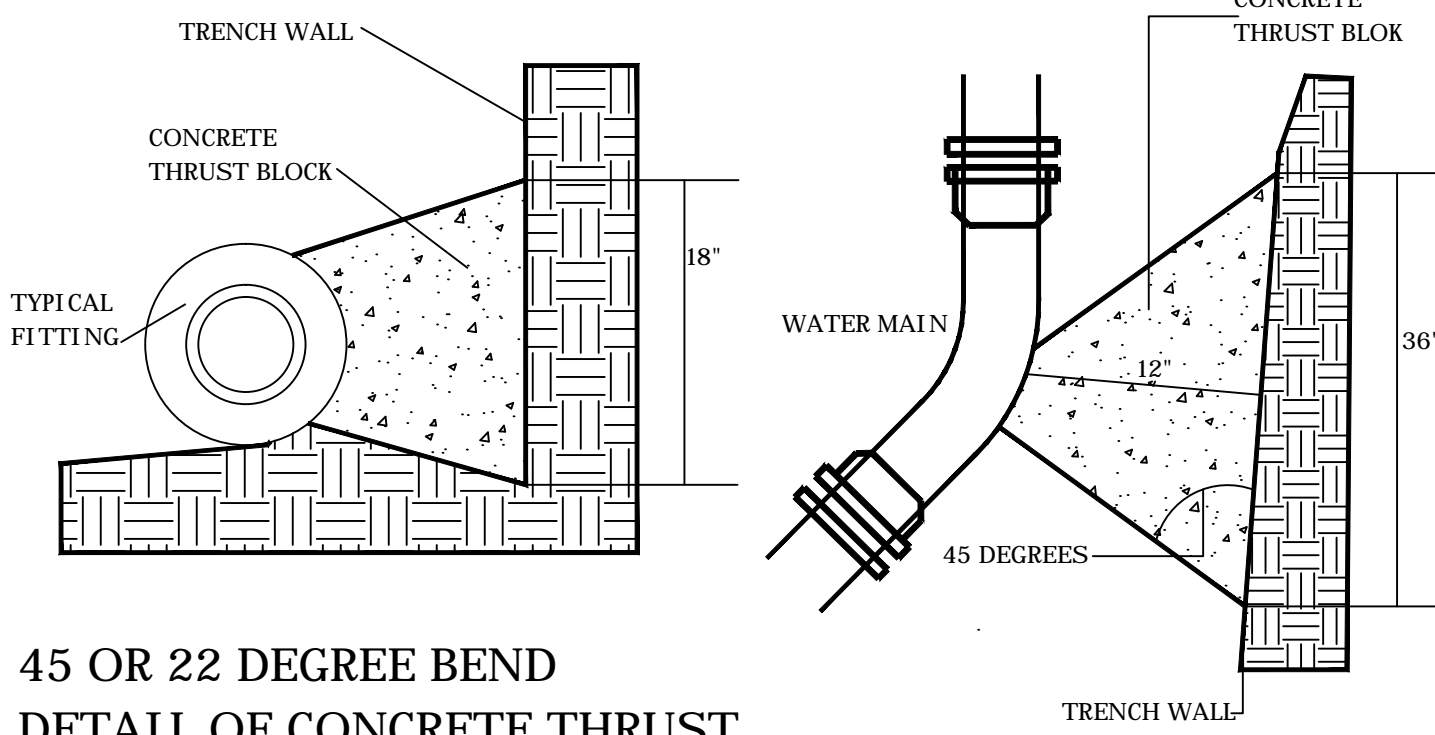

**45 OR 22 DEGREE BEND  
DETAIL OF CONCRETE THRUST  
BLOCK FOR WATER LINES  
NOT TO SCALE**

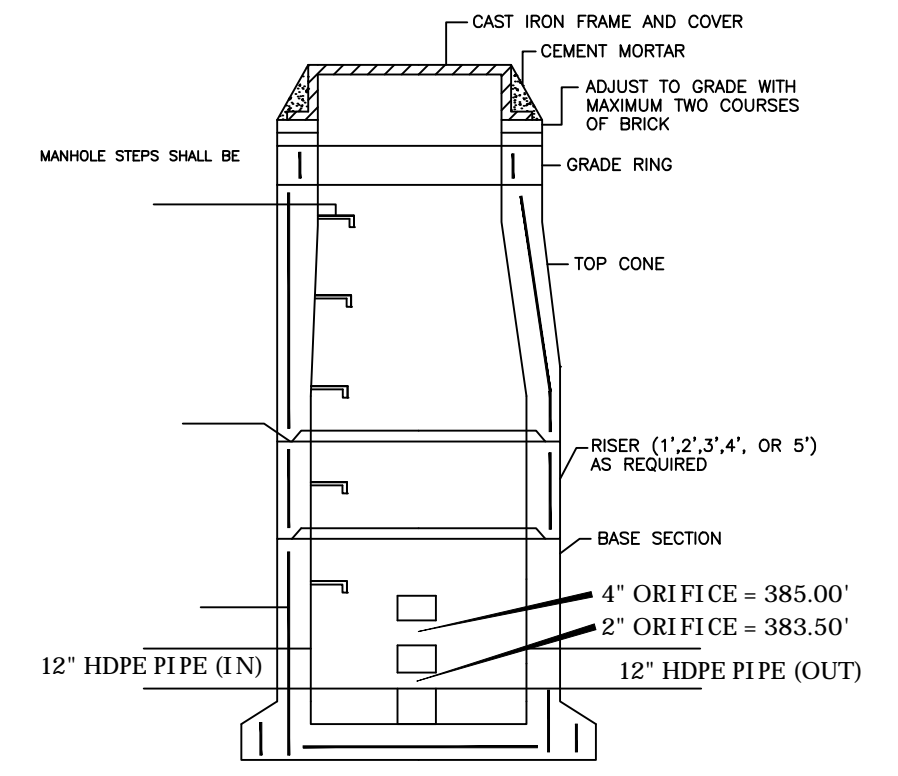

**OUTLET STRUCTURE MANHOLE  
NOT TO SCALE**

DRAINAGE SEWER MANHOLE TO BE MANUFACTURED IN ACCORDANCE WITH ASTM C-478

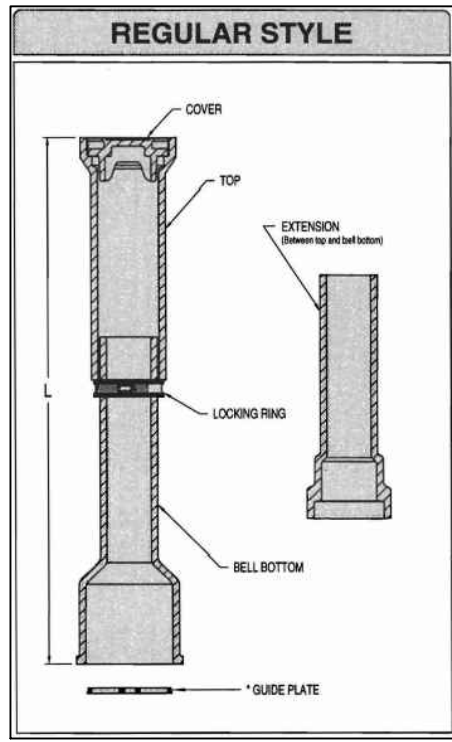

**Typical Curb Slide Valve Box Detail  
Not to Scale**



**Water Meter to be set in  
24" diameter meter pit**

Note: Water meter for single unit shall be 5/8" diameter for each new building.

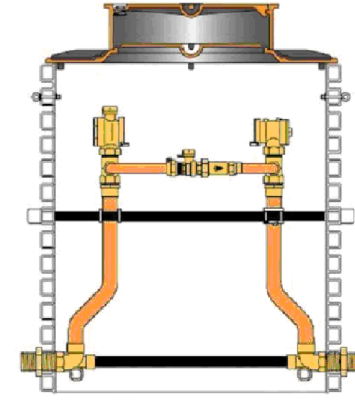

**Typical 24" diameter  
Meter Pit for water valve  
Not to Scale**

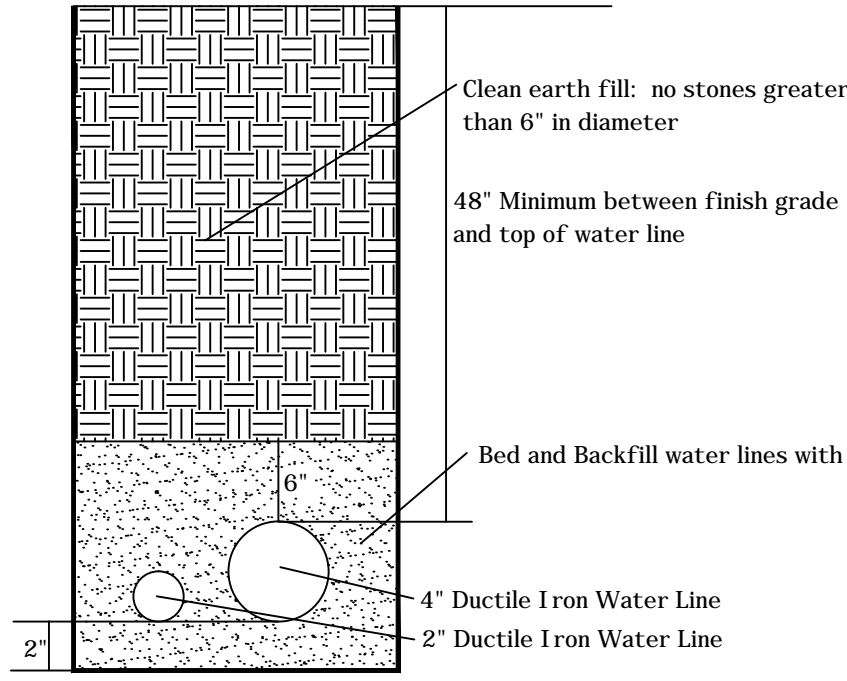

**TRENCH DETAIL FOR INSTALLATION  
OF WATER LINES  
NOT TO SCALE**

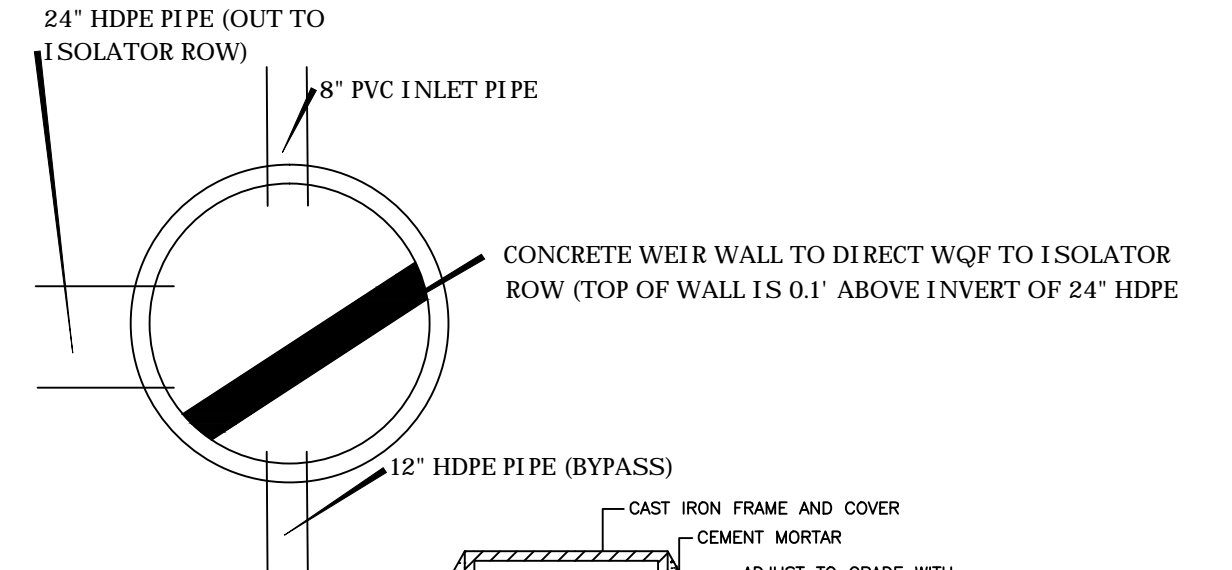

**WQF DRAINAGE MANHOLE  
NOT TO SCALE**

DRAINAGE SEWER MANHOLE TO BE MANUFACTURED IN ACCORDANCE WITH ASTM C-478

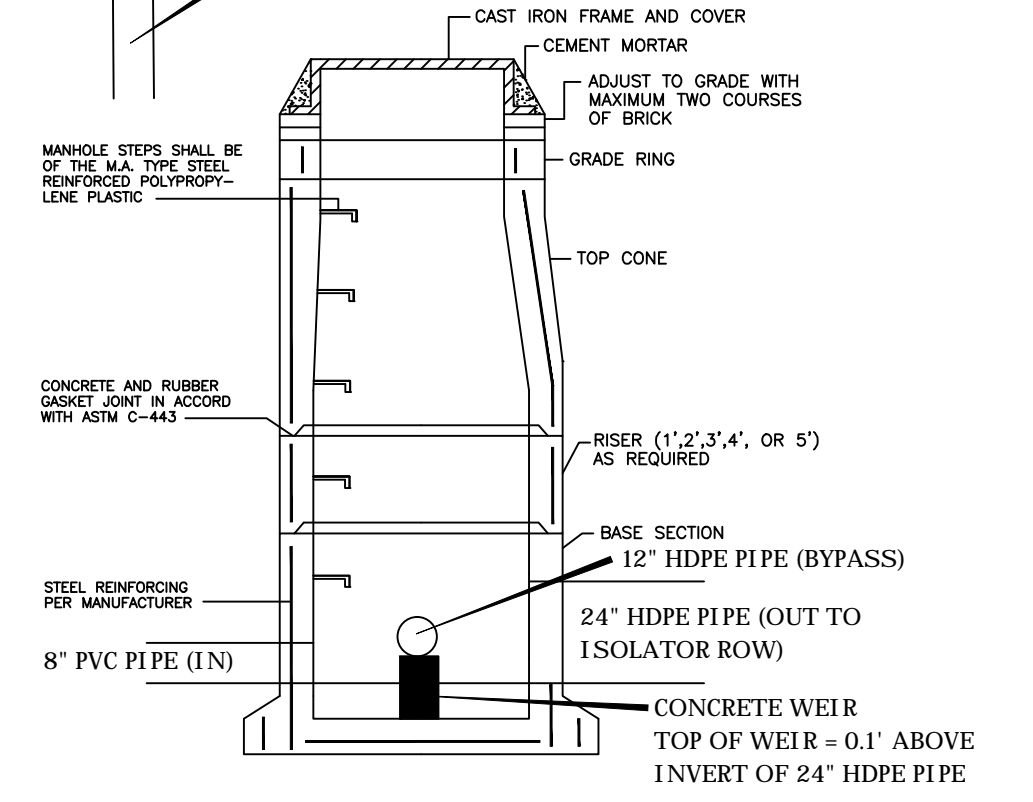

**WQF DRAINAGE MANHOLE  
NOT TO SCALE**

DRAINAGE SEWER MANHOLE TO BE MANUFACTURED IN ACCORDANCE WITH ASTM C-478

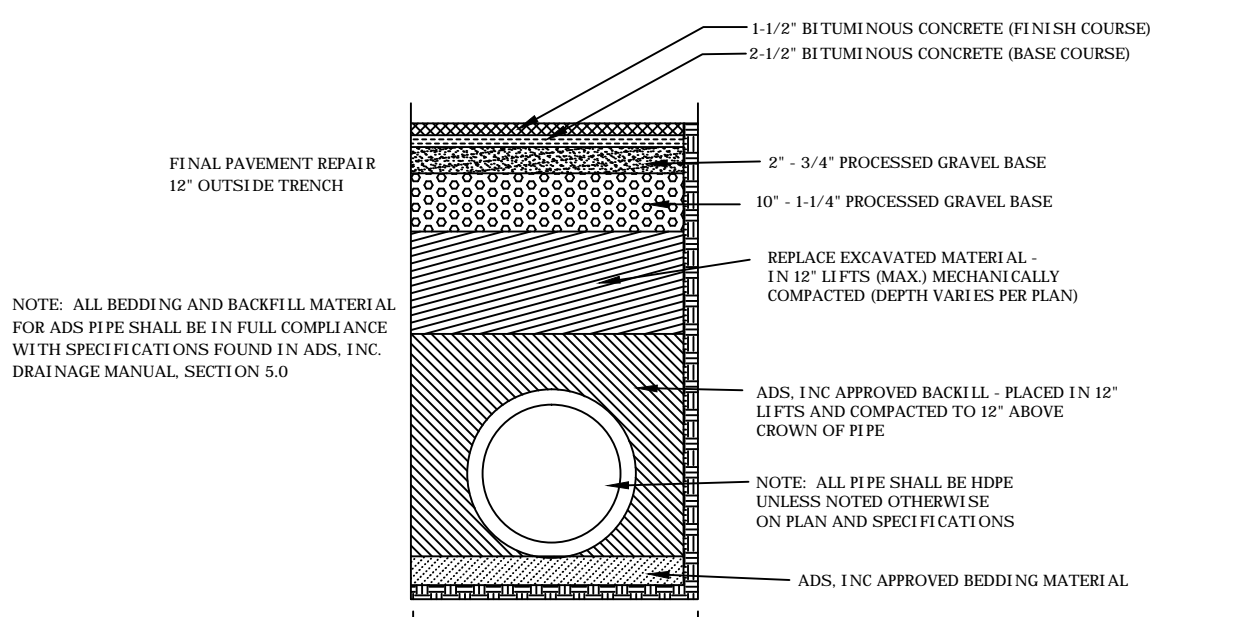

**TRENCH DETAIL - N.T.S.**

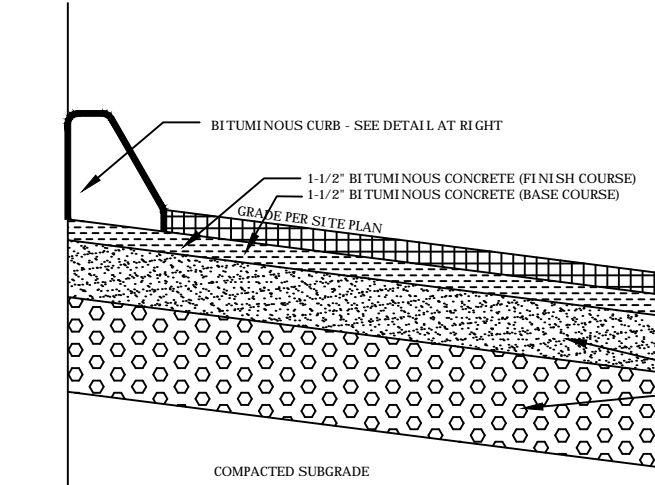

**CROSS SECTION OF STANDARD  
BITUMINOUS CONCRETE PAVEMENT  
NOT TO SCALE**

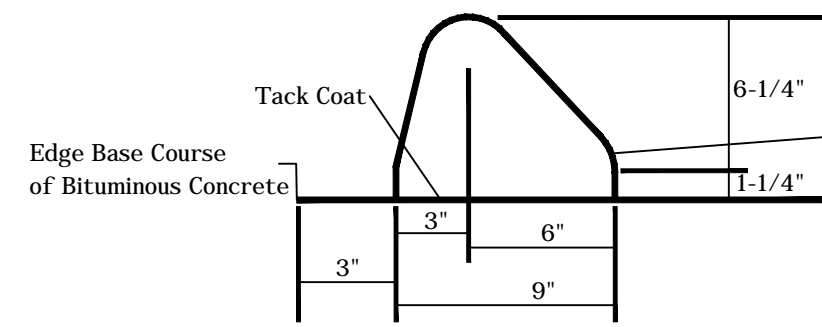

**BITUMINOUS CONCRETE CURBING  
NOT TO SCALE**

Lamp Type  
100 W Pulse Start Metal Halide

**DETAIL OF BOLLARD LIGHT  
FOR PARKING LOT  
N.T.S.**

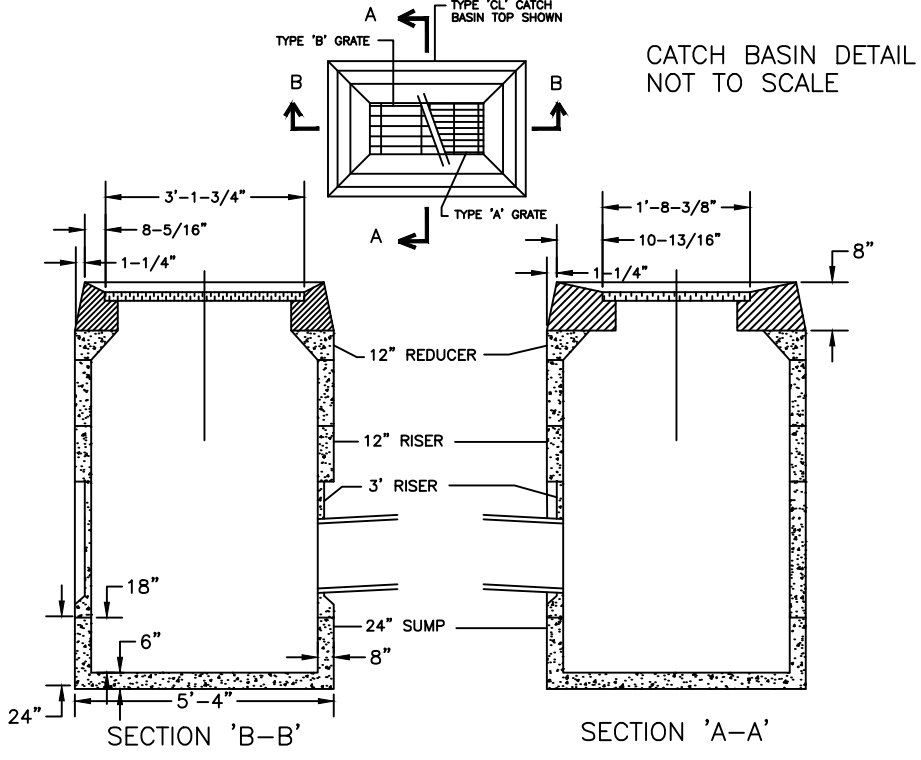
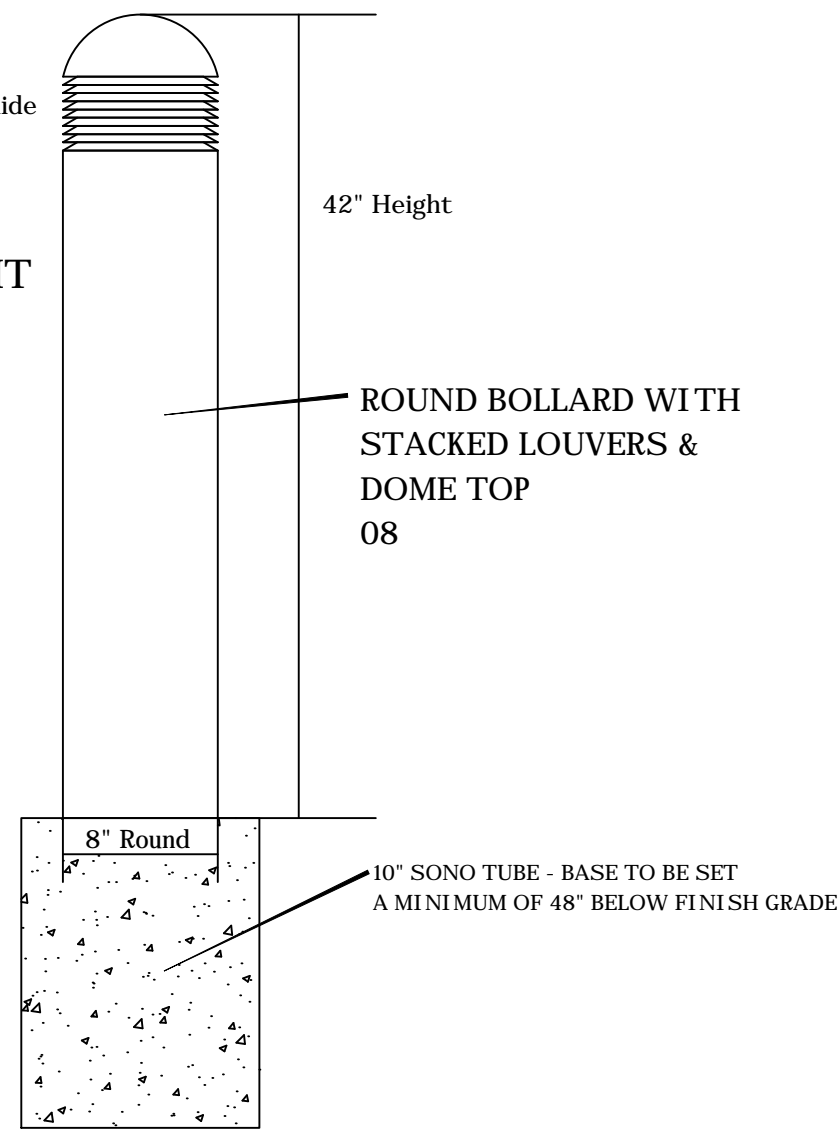

**CATCH BASIN DETAIL  
NOT TO SCALE**

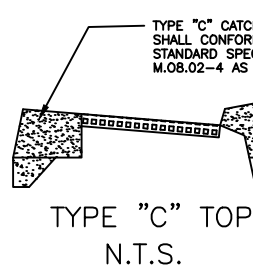

**TYPE "C" TOP  
N.T.S.**

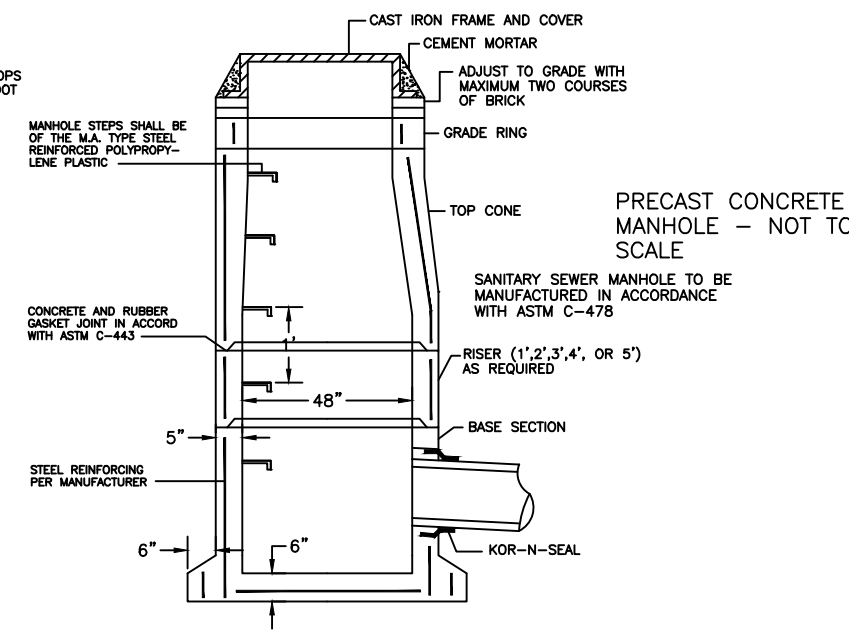

**DETAIL OF BOLLARD LIGHT  
FOR PARKING LOT  
N.T.S.**

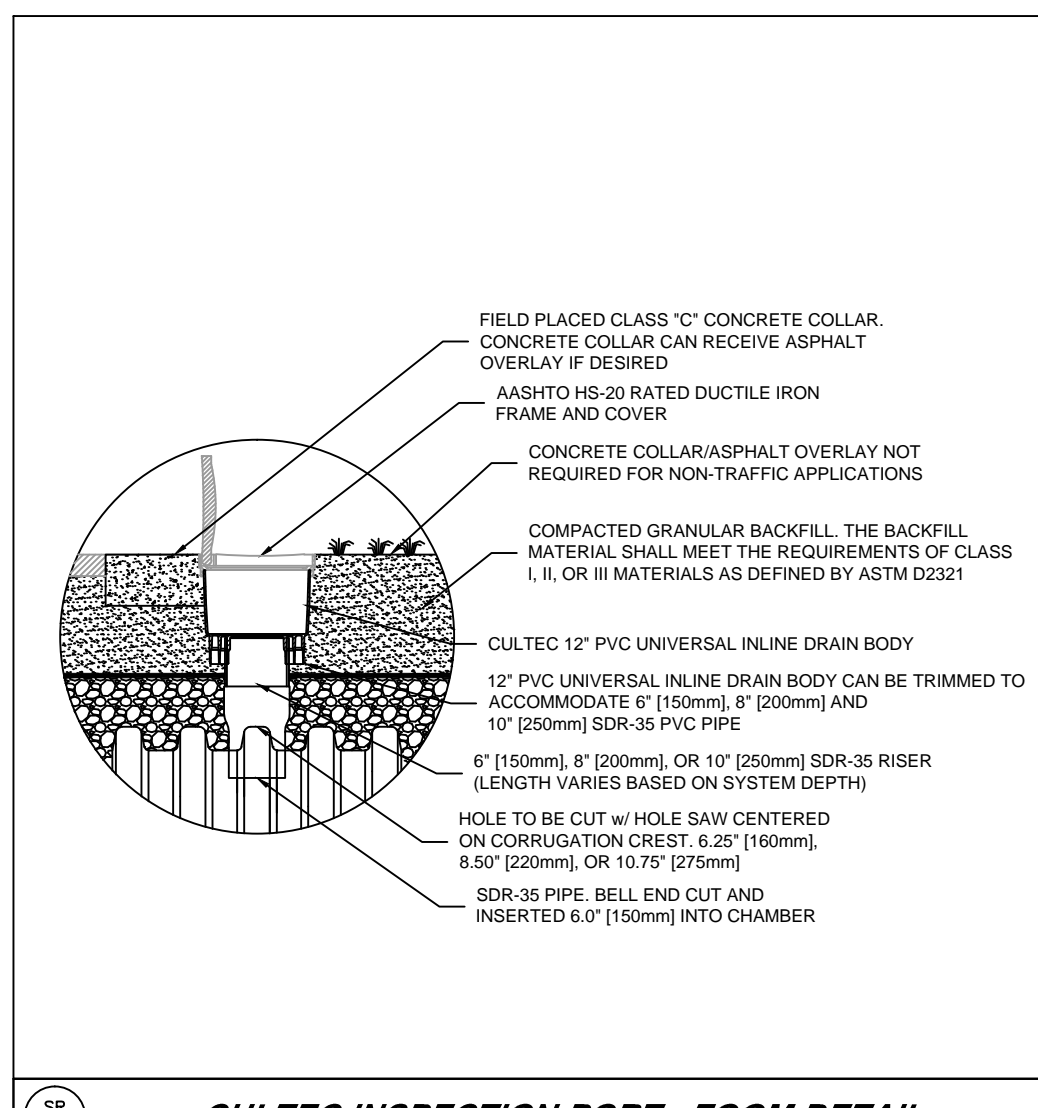

**CULTEC INSPECTION PORT - ZOOM DETAIL**

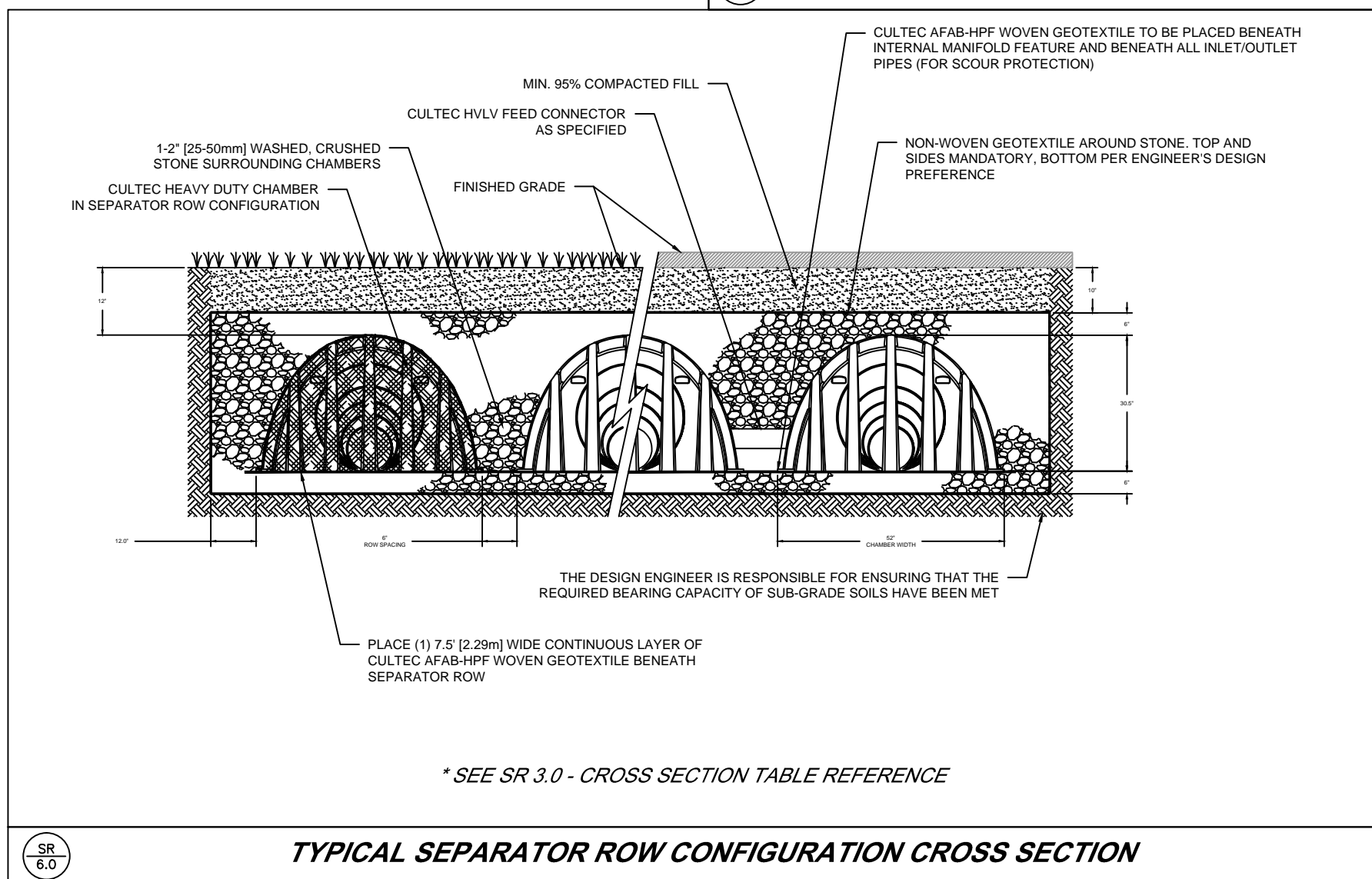

**TYPICAL SEPARATOR ROW CONFIGURATION CROSS SECTION**

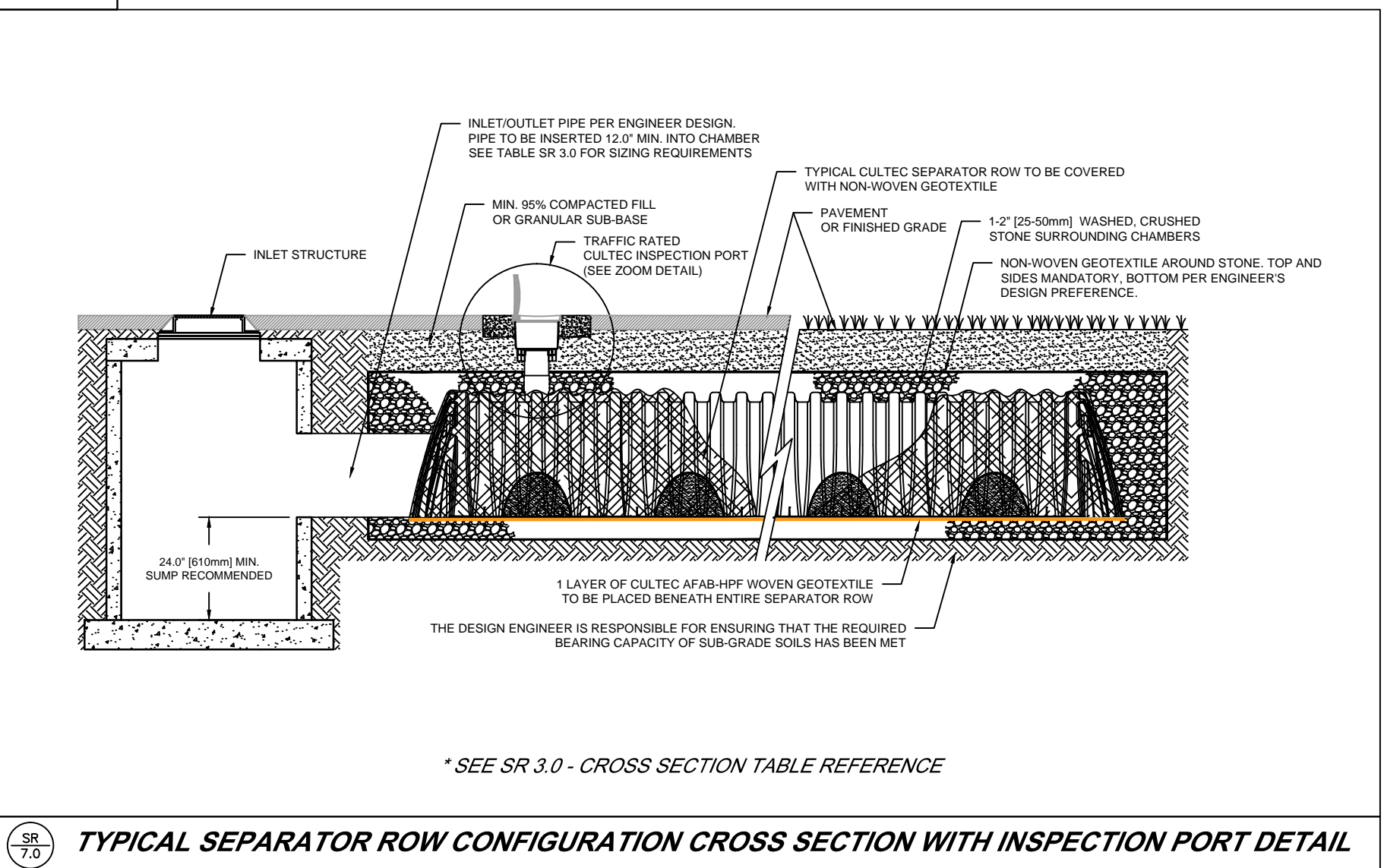

**TYPICAL SEPARATOR ROW CONFIGURATION CROSS SECTION WITH INSPECTION PORT DETAIL**

PREPARED FOR  
**D3 REALTY**  
72 RESERVOIR STREET  
BETHEL - CONNECTICUT

**CONSTRUCTION DETAILS**  
SHEET 5 OF 8  
SCALES AS NOTED  
PROJECT #042-2024  
DATE: 2/11/25, Rev. to 12/3/25



**TRINKAUS ENGINEERING, LLC**  
CIVIL ENGINEERS  
114 HUNTERS RIDGE ROAD  
SOUTHBURY, CONNECTICUT 06488  
203-264-4558 (phone)  
Email: strinkaus@earthlink.net  
Website: <http://www.trinkausengineering.com>

**EROSION AND SEDIMENTATION CONTROL PLAN - NARRATIVE**  
**PROPERTY LOCATION:** 0.75 acres - 72 Reservoir Road - Bethel, Connecticut  
**1.1 PROJECT DESCRIPTION:**

This project is located at 72 Reservoir Road in Bethel which was previously divided into two lots. The two parcels will be combined for this application. The land is vacant at the current time. It is proposed to construct three duplex homes on the combined parcel with all homes having a driveway onto Knollwood Drive. These homes will mirror the two on the east side of Knollwood Drive which were built by this applicant. The land slopes up to the south from Reservoir Road. Three test pits were excavated on the site which showed the depth of bedrock became shallower as you go up the slope. The slope will be excavated to create building pads for each duplex. A total of 10,100 cubic yards of soil and rock will be removed from the site to facilitate this construction. A ledge cut is shown on the site plan. Each unit will have a one-car garage and one space in front of the garage so two spaces per unit are provided. This project will be done under 8-30g of the Connecticut General Statutes, so two of the six units will be designated as affordable (1 at 80% & 1 at 60% of the statewide median income).

**1.2 ESTIMATED DISTURBANCE AREA:**

It is anticipated that 0.5 acres will be disturbed for the construction of the buildings, driveway & parking areas, and stormwater management system.

**1.3 EROSION CONTROL MEASURES:**

The following are erosion control measures to be utilized on this site during the construction period: Filtrexx Soxx, siltation fence barriers, stone construction entrances, and soil stockpiles

**1.4 CONSTRUCTION PHASES:**

There are no specific construction phases. Refer to sequence of construction below.

**1.5 CONSTRUCTION START DATES:**

It is anticipated that construction of the building may commence within 90 days after all necessary land use approvals are obtained from the Town of Bethel weather permitting.

**1.6 DESIGN INFORMATION:**

Maintenance specifications for the erosion control measures are part of this narrative. Construction sequences is provided below.

**1.7 OTHER PERMITS:**

No permits beyond the Town of Bethel are required.

**1.8 CONSERVATION PRACTICES:**

All runoff from the building roofs and driveway/parking area will be directed to an Isolator Row prior to being directed to the underground detention system which discharges to the Town of Bethel system.

**1.9 DOCUMENT LIST:**

1. Project Plan Set comprised of Sheet 1 thru 7 of 7.
2. Storm Water Management Report

**2.1 HYDRAULIC CALCULATIONS:**

The storm water management report contains the calculations for the Water Quality Volume, the Groundwater Recharge Volume and peak rate attenuation.

**2.2 SOIL TEST RESULTS:**

Three deep test holes were performed on the site. The soils are not suitable for infiltration.

**CONSTRUCTION SEQUENCE FOR NEW BUILDING/DRIVEWAY/PARKING AREAS:**

1. The limit of proposed ledge cut as well as the two side property lines shall be staked in the field by the project land surveyor.
2. Trees and brush shall be cleared from the area of the excavation. Woody debris shall be chipped and placed in a stockpile for temporary ground cover over earth areas during the excavation period.
3. The construction entrance shall be installed off Reservoir Road. Perimeter erosion control measures shall also be installed as shown on the site plan and in accord with the submitted details.
4. Excavation of soil shall commence at this time. Soil shall be placed in a stockpile area as shown on the site plan.
5. A pre-blast survey shall be done of the adjacent and/or nearby homes by the blasting company and required by the Fire Marshall.
6. Soil shall be removed by hydraulic excavator and placed in the stockpile area or removed from the site.
7. Rock removal shall commence at this time. Initially, rock will be removed by excavator as the upper layers of rock were well cracked in the test pits. Rock shall be removed from the site.
8. Blasting shall be used to remove the rock to a point two feet below the proposed finish ground elevations. This work shall be done under the supervision of the Fire Marshall.
9. After the site has been excavated, underground water and sanitary sewer lines from Knollwood Drive to the proposed residences.
10. Commencement of the three duplexes may commence at this time in accord with plans approved by the building department.
11. Utility connections shall be made to each building as shown. After the foundations have been installed and backfilled, the driveways shall be graded from Knollwood Drive to each duplex.
12. The stormwater water quality/detention system shall be installed in accordance with the approved plans. After the installation of the Cultec units, the connection shall be made to the existing drainage system on Knollwood Drive as shown.
13. After the connection has been made, the drainage above the detention system shall be installed.
14. After the driveway has been graded to the required subgrade, the trench drains shall be installed across each of the driveways and connected as shown on the site plan.
15. Boulder walls and finish grading shall be done at this time. A minimum of 6" of topsoil shall be placed over all disturbed areas, seeded and covered with straw mulch.
16. All erosion control measures shall remain in place and in effective condition until a permanent vegetative cover has been established.

**LONG TERM MAINTENANCE SCHEDULE:**

Best Management Practices (BMP's) program, for post-development conditions on the project has been developed to manage both the storm water quality. The recommendations are proposed to protect the site and downgradient wetland areas.

The success of the BMP controls requires professional and regulatory input, and monitoring through the implementation of a long-term maintenance program.

**PLAN OBJECTIVES AND PRINCIPALS:**

The objectives of the Soil Erosion and Sediment Control Plan are to manage both the runoff and the earthwork operations by using Best Management Practices. The objectives are as follows:

- a. Control erosion at its source with temporary control measures, minimize the runoff from areas of disturbance, distribute stormwater through natural vegetation before being discharged into wetland systems.
- b. Keep land disturbance to a minimum.
- c. Construct the project in phases to minimize the area of the site under active construction at one time.
- d. Retain existing vegetation wherever feasible. Siltation fence or other barriers will be used to limit the extent of earthwork. Substantial buffers will be provided to the wetland/watercourse systems.
- e. Stabilize disturbed areas as soon as practical. Earth disturbance shall not occur on a given area until active construction is to take place in this area.
- f. Minimize the length and steepness of slopes.
- g. Maintain low runoff velocities.
- h. Trap sediment on site. Siltation fence barriers and road construction entrance will trap sediment during the construction period.
- i. Establish a maintenance and repair program during the construction period. Erosion control measures will be inspected weekly during the spring months, twice a month during the summer and/or following rainfall events of greater than 0.5 inches and repaired as needed to ensure that they function properly.
- j. Assign responsibility for the maintenance program. The responsibility for the maintenance program will be assigned to the contractor who shall designate one of its supervisory personnel to be the liaison to the owner's representative. The owner shall retain the services of a licensed professional who shall inspect and monitor the contractor's methods and have the authority to require modifications to the Erosion and Sediment Control Plan. The town will be copied on all inspection reports prepared on behalf of the project.

**TEMPORARY EROSION AND SEDIMENT CONTROL MEASURES - MAINTENANCE REQUIREMENTS:**

1. Siltation Fence Barriers: All barriers shall be installed in accordance with the detail shown on the plans, sediment shall be removed from behind the siltation fence when sediment has accumulated to 25% of the original height of the fence.
2. Dust Control: Water shall be applied by sprinkler or water truck as necessary during the grading operations to minimize sediment transport and maintain acceptable air quality conditions. Repetitive treatments will be done as needed until grades are paved or seeded.
3. Construction Entrance: Entrances shall be inspected every two months during the active construction period. If sediment is clogging the stone surface, an additional layer of crushed stone shall be added to the Construction Entrance.

**CONTROL PLAN IMPLEMENTATION:**

1. The contractor shall inspect the effectiveness and condition of erosion control devices during storm events, and after each rainfall event of 0.5" or more, prior to weekends and prior to forecasted large storm events.
2. The contractor shall repair or replace damaged erosion control measures immediately, and in case, more than four hours after observing such deficiencies.
3. The contractor shall be prepared to implement interim drainage controls and erosion control measures as may be necessary during the course of construction.
4. The contractor shall make available on-site all equipment, materials and labor necessary to effect emergency erosion control measures within four hours of any impending emergency situation.
5. The contractor shall make a final inspection, clean all cross culverts and sweep off roadways before the road is dedicated to the town.
6. The contractor shall have on call at all times, a responsible representative who, when authorized, will mobilize the necessary personnel, materials and equipment and otherwise provide the required action when notified of any impending emergency situation.
7. The contractor shall supply a telephone number to the town engineer, planning agent so that the contractor may be contacted during the evenings and on weekends, if necessary.
8. The contractor shall maintain a minimum of 100 lf of silt fence on the site for use during emergencies during the development of the project.

**GENERAL EROSION AND SEDIMENTATION CONTROL PLAN NOTES:**

1. Regrading on this site shall done in such a manner as to prevent stagnant water from collecting in depressions.
2. All erosion and sedimentation control measures will be installed prior to the start of any construction activity.
3. All erosion and sedimentation control measures shall be constructed in accordance with the submitted construction details and in compliance with the specifications and standards found in the "Guidelines for Soil Erosion and Sediment Control" as prepared by the State of Connecticut, revised to 2024.
4. Siltation fence barriers will be installed at the limit of all disturbed areas. Staked straw bales, will be utilized as necessary during the construction period. All work done shall be in accordance with the details shown on the plans.
5. Land disturbance will be kept to a minimum. Restabilization of all disturbed areas will occur as soon as final grading is complete.
6. All erosion and sedimentation control measures will be maintained in an effective conditions throughout the construction period.
7. Accumulated sediment will be removed from the control structures and disposed of in a lawful and safe manner.
8. Additional control measures will be installed during the construction period if the Zoning or Wetland Enforcement Officer requires them. The design engineer shall inspect the site periodically to ensure the proper installation of erosion control measures.
9. Regular inspections of the construction site shall be made by a representative of the Town of Bethel and a professional retained by the owner to assure compliance with the approved plans.
10. The responsibility for implementing the erosion and sedimentation control plan, informing all parties engaged on the construction site of the requirements and objectives of the plan, notifying the appropriate town agencies of any transfer of this responsibility and for conveying a copy of the erosion and sedimentation control plan if title to the land is transferred is place upon the owner of record.

**SEEDING MIXTURES FOR AREAS TO BE MAINTAINED AS GRASS:**

MIXTURE #1	
KENTUCKY BLUEGRASS	20 LBS/ACRE
CREeping RED FESCUE	20 LBS/ACRE
PERENNIAL RYEGRASS	5 LBS/ACRE
MIXTURE #2	
CREeping RED FESCUE	20 LBS/ACRE
REDTOP	2 LBS/ACRE
TALL FESCUE	20 LBS/ACRE

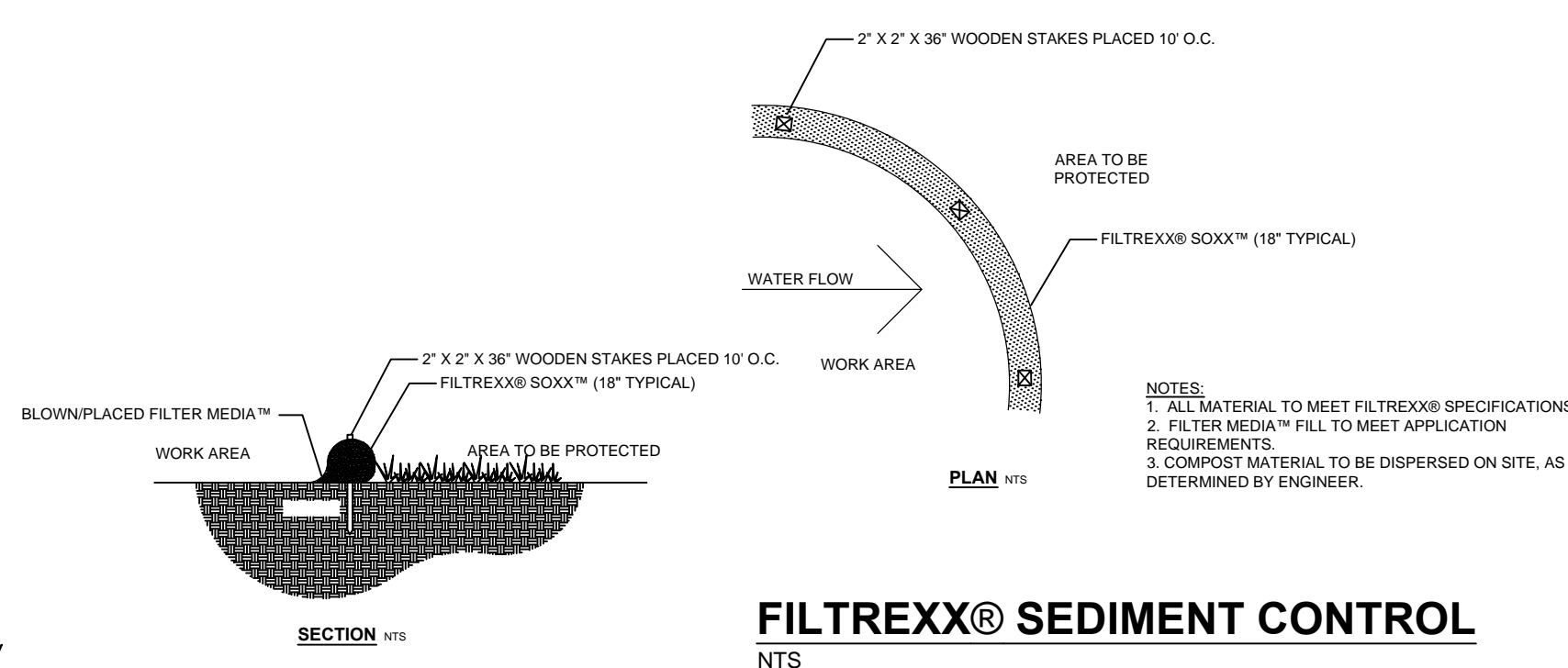
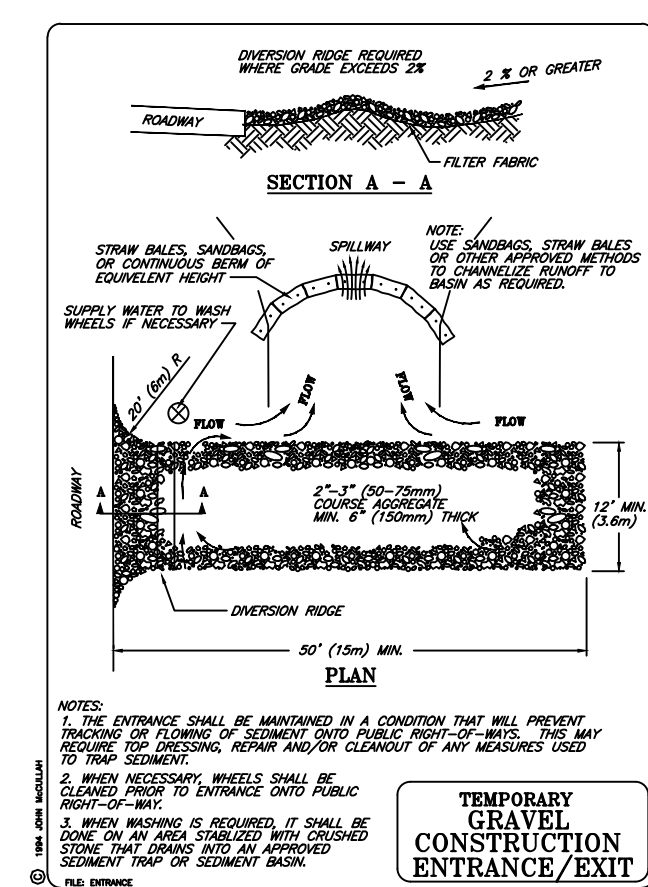
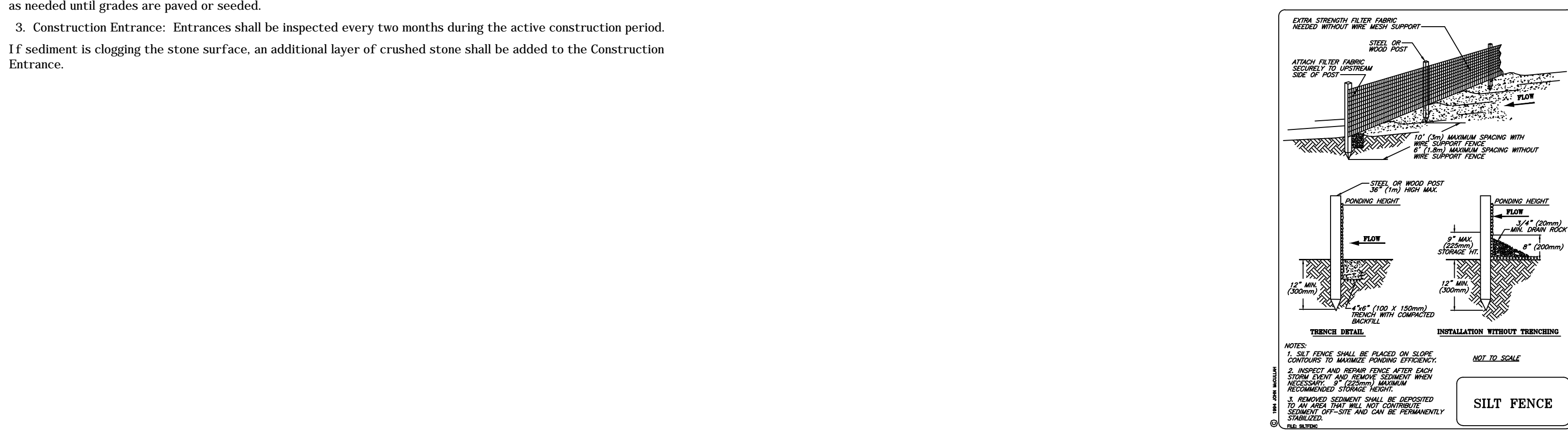

**Important Note:**  
 Additional underground utilities may exist  
 Prior to any excavation or construction,  
 contact: "CALL BEFORE YOU DIG" 1-800-922-4455 or 811

**PREPARED FOR**  
**D3 REALTY**  
**72 RESERVOIR STREET**  
**BETHEL - CONNECTICUT**

**NARRATIVE**  
 SHEET 6 OF 8  
 SCALES AS NOTED  
 PROJECT #042-2024  
 DATE: 2/11/25, Rev. to 12/3/25

**TRINKAUS ENGINEERING, LLC**  
 CIVIL ENGINEERS  
 114 HUNTERS RIDGE ROAD  
 SOUTHBURY, CONNECTICUT 06488  
 203-264-4558 (phone)  
 Email: strinkaus@earthlink.net  
 Website: http://www.trinkausengineering.com

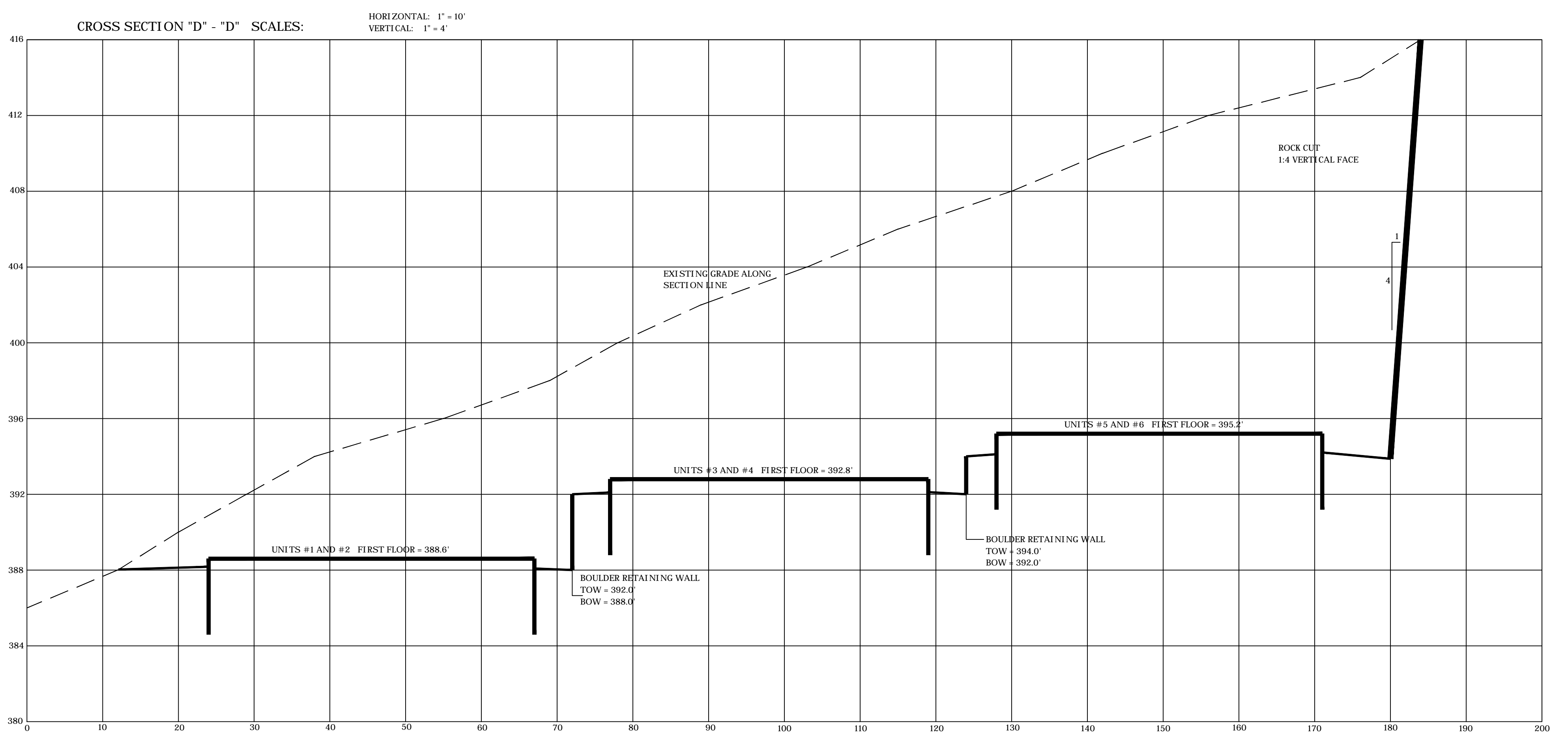
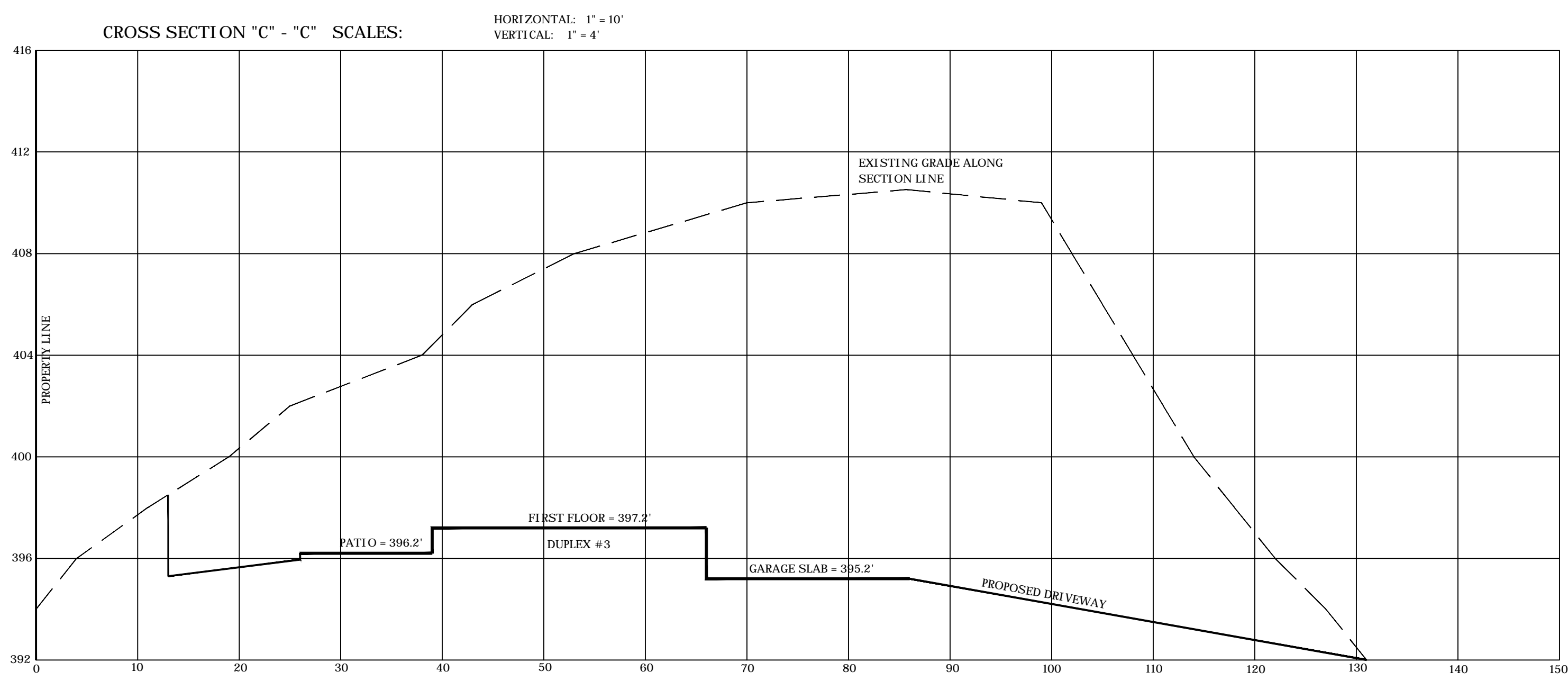
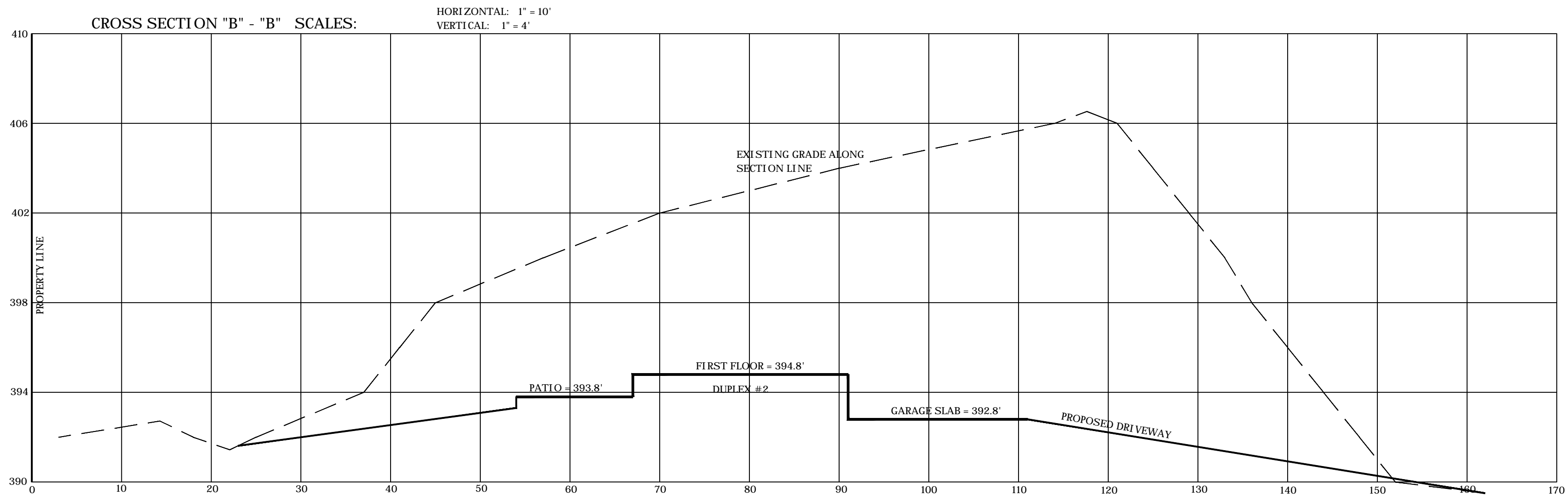
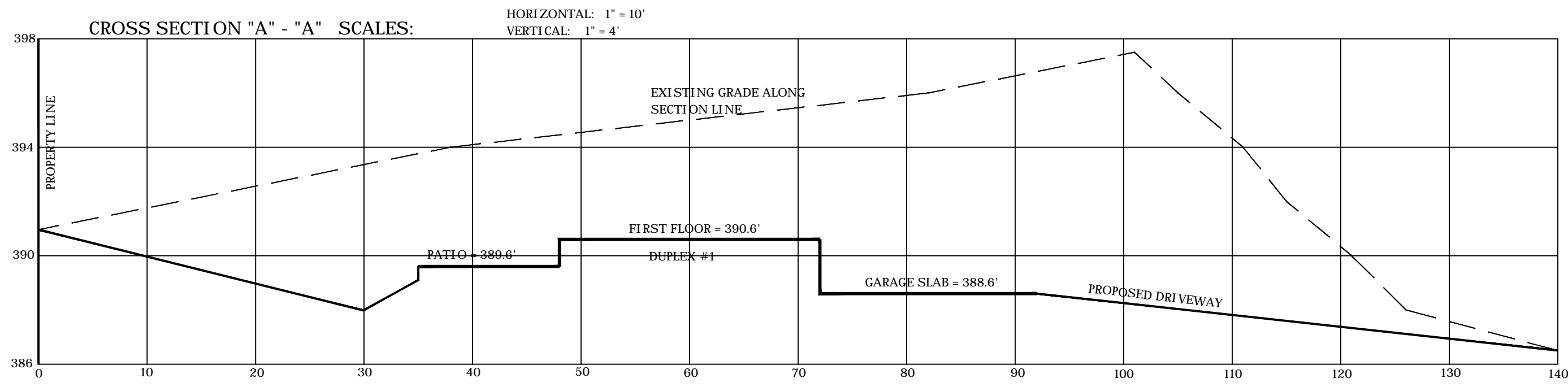

*Important Note:*  
 Additional underground utilities may exist  
 Prior to any excavation or construction,  
 contact: "CALL BEFORE YOU DIG" 1-800-922-4455 or 811

PREPARED FOR  
 D3 REALTY  
 72 RESERVOIR STREET  
 BETHEL - CONNECTICUT

## CROSS SECTIONS

SHEET 7 OF 8  
 SCALE: 1" = 20'  
 PROJECT #042-2024  
 DATE: 2/11/25, Rev. to 12/3/25



TRINKAUS ENGINEERING, LLC  
 CIVIL ENGINEERS  
 114 HUNTERS RIDGE ROAD  
 SOUTHURY, CONNECTICUT 06488  
 203-264-4558 (phone)  
 Email: strinkaus@earthlink.net  
 Website: <http://www.trinkausengineering.com>

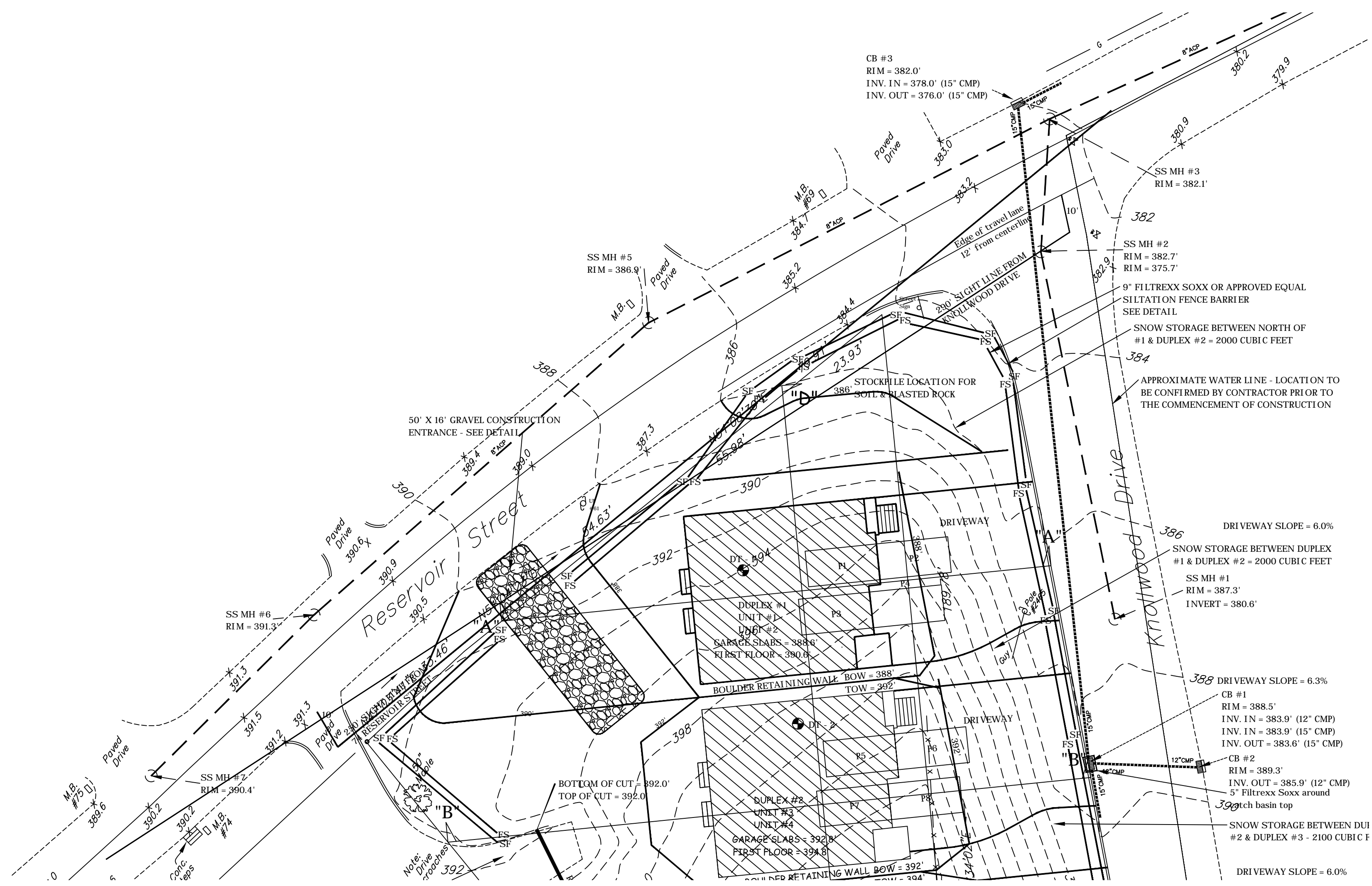
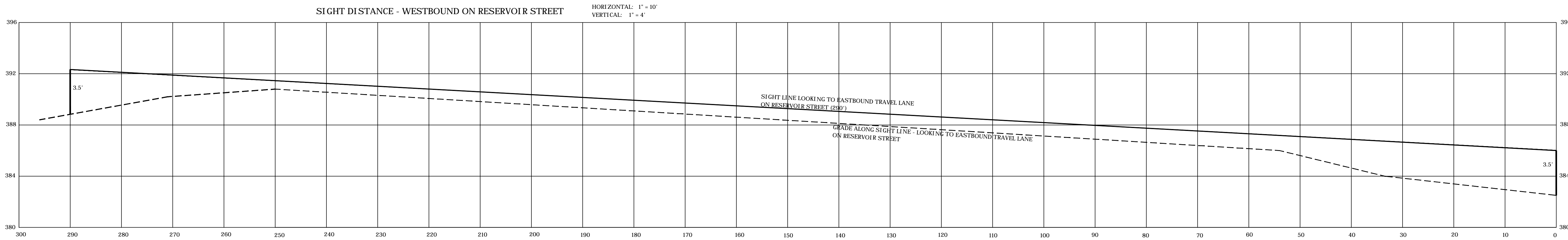
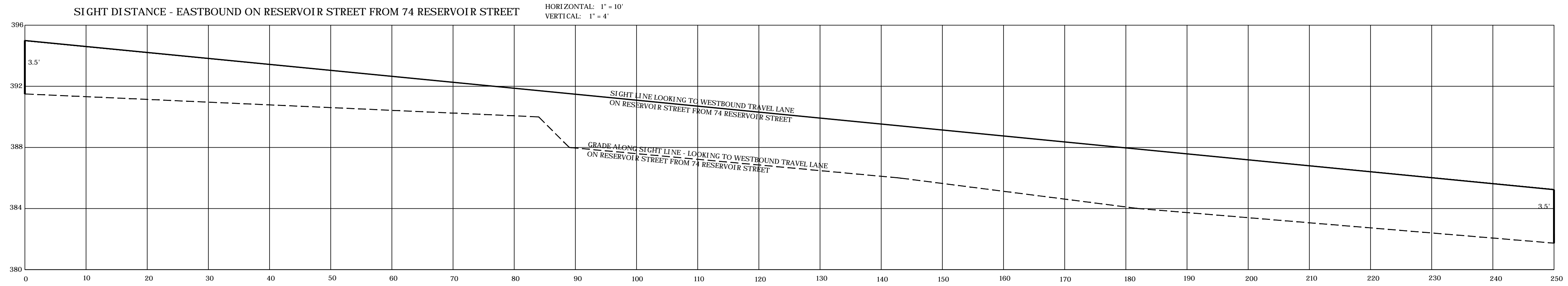

*Important Note:*  
Additional underground utilities may exist  
Prior to any excavation or construction,  
"CALL BEFORE YOU DIG" 1-800-922-4455 or 811  
contact:

**TRINKKAUS ENGINEERING, LLC**  
CIVIL ENGINEERS  
114 HUNTERS RIDGE ROAD  
SOUTHBRURY, CONNECTICUT 06488  
203-264-4558 (phone)  
Email: strinkkaus@earthlink.net  
Website: <http://www.trinkausengineering.com>



**SIGHT DISTANCE PLAN**  
SHEET 8 OF 8  
SCALE: 1" = 20'  
PROJECT # 042-2024  
DATE: 2/11/25, Rev. to 12/3/25

**PREPARED FOR**  
**D3 REALTY**  
**72 RESERVOIR STREET**  
**BETHEL - CONNECTICUT**